



TELEDYNE BATTERY PRODUCTS

DRY-CHARGED LEAD-ACID AIRCRAFT BATTERY SERVICE MANUAL

PROPOSITION 65 WARNING

BATTERY POSTS, TERMINALS AND RELATED ACCESSORIES CONTAIN LEAD AND LEAD COMPOUNDS,
CHEMICALS KNOWN TO THE STATE OF CALIFORNIA TO CAUSE CANCER AND REPRODUCTIVE HARM.
WASH HANDS AFTER HANDLING.

Receipt and use of this technical document by any receiving party is subject to compliance with all decrees, statutes, rules and regulations of the United States Government and of the Governments of the countries in which Teledyne Battery Products and the receiving party are doing business at the time of receipt by the receiving party in effect, or which may be in effect hereafter, which govern exports or otherwise pertains to export controls, including without limitation, the Export Administration Regulations and the International Traffic in Arms Regulations.

WARNING

THE SAFETY INSTRUCTIONS/PRECAUTIONS POSTED IN VARIOUS SECTIONS WITHIN THIS MANUAL
MUST BE STRICTLY FOLLOWED.

ALWAYS WEAR SAFETY GLASSES AND ACID-RESISTANT GLOVES WHENEVER HANDLING BATTERIES
ELECTROLYTE CONTAINS SULFURIC ACID, WHICH CAN PERMANENTLY DAMAGE EYES AND CAUSE
SEVERE BURNS TO EXPOSED SKIN.

FOR LIMITATIONS, PROCEDURES AND PERFORMANCE INFORMATION NOT CONTAINED IN THIS SUPPLEMENT CONSULT THE
BASIC PILOTS OPERATING HANDBOOK, AIRPLANE FLIGHT MANUAL, THE SPECIFIC STC OR THE BATTERY CONTINUOUS
AIRWORTHINESS INSTRUCTIONS FOR THE APPLICATION.
THIS SERVICE MANUAL SHOULD NOT BE CONSTRUED AS THE FINAL AUTHORITY IN MAINTAINING YOUR SPECIFIC BATTERY.
PLEASE CONSULT WITH TELEDYNE TECHNICAL SUPPORT FOR FURTHER INFORMATION.



Gill *DRY CHARGE SERVICE MANUAL*

CONTENTS

<u>Section</u>		<u>Page</u>
1	REVISION PAGE	1
2	SCOPE	2
3	INTRODUCTION	3
4	DRY-CHARGED LEAD-ACID BATTERIES	4
	4.1 Description	4
	4.2 Specification Definitions	4
	4.3 Temperature Effects	5
	4.4 Life Expectancy	6
5	PREPARING DRY-CHARGED BATTERIES FOR USE	8
	5.1 Tools Needed	8
	5.2 Filling (or Activation)	8
6	INSTALLATION	14
	6.1 Battery Installation Pre-Verification	14
	6.2 Battery Ventilation	14
	6.3 Sump Jar Treatment	15
	6.4 Ventilation System Requirements	15
7	SERVICING	16
	7.1 Service Requirements	16
	7.2 Connector/Wiring Inspection	16
	7.3 Electrolyte Levels	17
	7.4 Sump Jar Maintenance	19
	7.5 Managing Periods of Non-Use	19
	7.6 Shelf Life and Storage Conditions	19
	7.7 Continued Airworthiness Determination	21
	7.8 Charging	22
	7.8.7 Constant-Current (CI)	23
	7.8.8 Constant-Voltage (CV)	24
	7.9 Recharging Deeply Discharged Batteries	25
	7.10 Battery Safety	26



Gill DRY CHARGE SERVICE MANUAL

<u>Section</u>	<u>Page</u>
7.11 Jump Starting an Engine	28
8 RECYCLING	29
8.1 Material Safety Data Sheets	29
8.2 Recycler Locations	29
8.3 International Recycling Resources	30
9 FAQ'S	31
10 GLOSSARY	34
11 TROUBLE SHOOTING	35
12 APPENDIX A Battery Specifications	39
13 APPENDIX B Using a Hydrometer	59
14 APPENDIX C Activation and Service Instructions for Gill Dry-Charged Lead-Acid Aircraft Batteries (TBP 1560)	62



COMPONENT MAINTENANCE MANUAL

REVISIONS

Revision	Description of Change	Approved By	Date
NC	Completely Revised	JMR	7-15-03
A	Added new load tester	JMR	8-31-04
B	Corrected manual number	JMR	6-30-05
C	Revised load test conditions	JMR	8-17-07
D	Revised Activation and Service Instructions; added other graphics	JMR	7-30-08
E	Revised	JMR	5-6-13
F	Revised references to Appendixes, Troubleshooting Section	JMR	4-2-14
G	Revised 7.5.2	JMR	9-8-14
H	Revised 7.7.1	JMR	12-3-14
J	Corrected service instruction language	JMR	7-8-15
K	Revised Section 7.7	JMR	12-5-16



COMPONENT MAINTENANCE MANUAL

SCOPE

This manual provides Maintenance Procedures for Gill Dry-Charged Lead Acid Aircraft Batteries manufactured under FAA Parts Manufacturer Approvals (PMA).

This manual has been written for the purpose of guidance only; consult Teledyne Battery Products Technical Support for further information.

The latest list of our PMA's can be obtained on our website at: www.gillbatteries.com or by calling our Customer Support at (800) 456 0070.



COMPONENT MAINTENANCE MANUAL

INTRODUCTION

Teledyne Battery Products of today had a modest beginning in the early 1920's under the Stewardship of Mr. Lawrence Gill. Since inception, Gill has been producing first rate batteries primarily for the aircraft industry. In the 1960's, Gill Electric was sold to Teledyne, acquiring the new name of Teledyne Battery Products.

Gill has introduced most of the innovations in the industry, including 24 volt batteries for light aircraft and low impedance, high power batteries for the turbine fleet. Meeting the stringent weight requirements, it was a Gill battery that powered the Voyager's electrical systems and avionics on its record-breaking non-stop around-the-world flight.

Given our demonstrated ability of building batteries that have predictable characteristics to narrow specifications, we are chosen as original equipment by most airframe manufacturers and are the popular choice for replacement. Many design innovations contribute to the value of a Gill aircraft battery, such as:

- Through-the-partition intercell welding.
- Enveloped plates.
- Improved case-cover seal.
- Heavy-duty internal post.
- Redesigned cell construction to provide better power delivery and charge acceptance.

Whether cranking a piston engine, spooling a demanding jet turbine or high-output applications in business jets, turboprops and helicopters, Teledyne Battery Products has the right power source for the job!

Teledyne Battery Products is committed to utilizing/developing synergies within the Teledyne group of companies to continue providing unsurpassed product integration enabling customers' ease of use and reliability.



COMPONENT MAINTENANCE MANUAL

DRY-CHARGED LEAD-ACID BATTERIES

4.1 DESCRIPTION

- 4.1.1 These batteries are assembled with electrodes (plates) that have been fully charged and dried. The dried plates are quite stable over time, allowing the batteries to be stored indefinitely.
- 4.1.2 Each cell is tightly sealed prior to shipment. These seals must not be tampered with during storage and should only be removed just prior to activation with electrolyte. Battery life begins when the electrolyte is added.
- 4.1.3 It is recommended that these batteries be stored in cool, dry areas, as high humidity and temperature will only serve to discharge the negative plates, requiring considerable conditioning if the oxidation is severe.

4.2 SPECIFICATION DEFINITIONS

Gill aircraft batteries are defined by a series of specifications:

4.2.1 The One-Hour Rate

This is the rate of discharge a battery can endure for one hour with the battery voltage at or above 1.67 volts per cell, or 20 volts for a 24 volt lead-acid battery, or 10 volts for a 12 volt lead-acid battery.

The One-Hour Capacity, measured in Ampere Hours or Ah, is the product of the discharge rate and time (in hours) to the specified end voltage.

4.2.2 The Emergency Rate

This is the rate of discharge a battery can endure for thirty minutes with the battery voltage at or above 1.67 volts per cell, or 20 volts for a 24 volt lead-acid battery, or 10 volts for a 12 volt lead-acid battery.

The Emergency Rate is the total essential load, measured in amperes, required to support the essential bus for thirty minutes.



4.2.3 State of Charge

State of Charge is a quick reference to the state of health of a battery. These voltage measurements should be used as a guide only. Note Figure 1, which indicates the relationship between Open-Circuit Voltage (No-Load Voltage, OCV) and % State-of-Charge (SOC) for Dry-Charged Products.

Please note that state-of-charge is not the same as available capacity (see GLOSSARY).

Figure 1

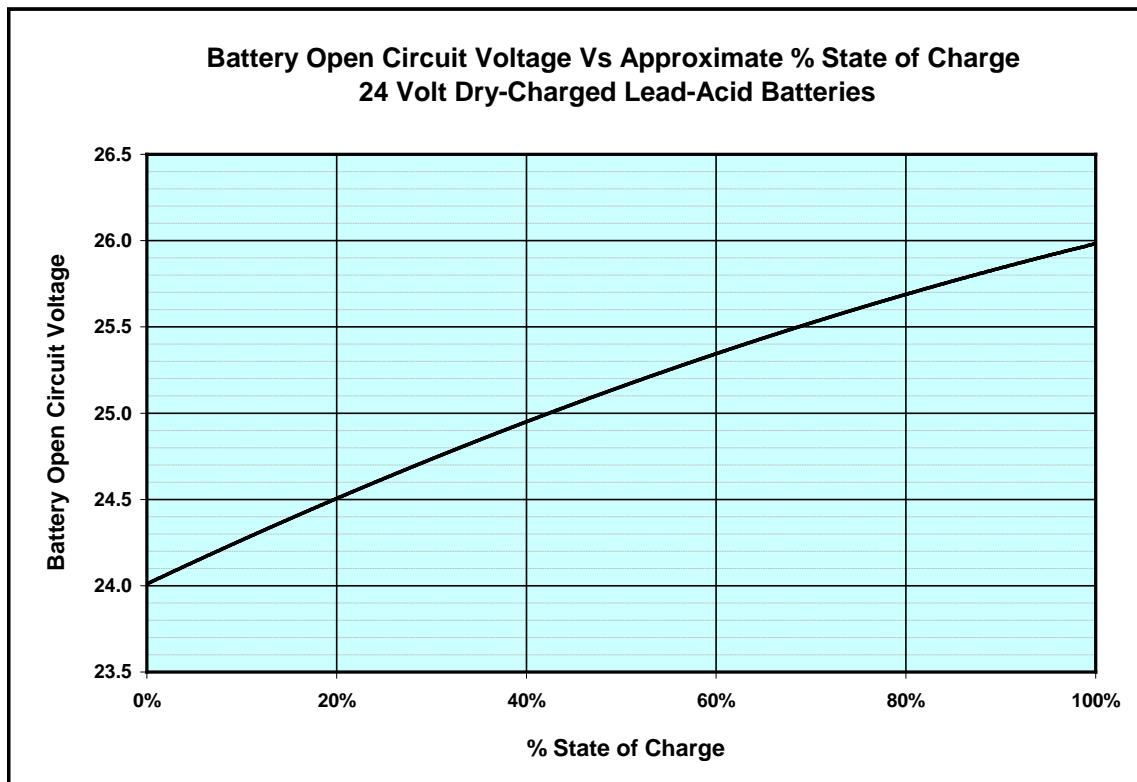

4.3 TEMPERATURE EFFECTS

4.3.1 External temperatures will alter electrolyte viscosity - in turn affecting the current developing characteristics of the battery. Lower temperatures will generally result in reduced power performance.

4.3.2 The freezing point of electrolyte is quite low. However, a discharged battery, with lower specific gravity electrolyte, will tend to freeze at higher



Gill DRY-CHARGE MAINTENANCE MANUAL

temperatures. Note Table 1 for electrolyte freezing points with varying electrolyte strength (sulfuric acid concentration).

4.3.3 Charge acceptance at low temperatures (less than 30°F) is generally low. It is preferred to charge batteries at higher temperatures (30°F to 90°F).

**Table 1
FREEZING POINT OF ELECTROLYTE**

Specific Gravity	Freezing Point	
	°F	°C
1.285	-85	-65
1.250	-61	-52
1.225	-35	-37
1.200	-17	-27
1.175	-4	-19
1.150	+5	-15
1.125	+13	-10
1.100	+18	-7.7

4.4 LIFE EXPECTANCY

4.4.1 Typical battery failure mode should be complete non-reversible utilization of active material. A battery that is operated and maintained per manufacturers guidelines should deliver several years of useful service.

However, actual service life varies due to several factors:

4.4.2 Charging variations

4.4.2.1 Improper voltage settings

- Note recommended voltage settings in Table 2. Make sure that the voltage regulators are correctly adjusted.

4.4.2.2 Overcharging

- Overcharging could result from leaving a battery on charge too long at voltages higher than recommended. This will result in deterioration of the active material and accelerated grid corrosion.

Premium Aircraft Batteries
 TELEDYNE BATTERY PRODUCTS
 www.gillbatteries.com
 800.456.0070



Gill DRY-CHARGE MAINTENANCE MANUAL

- 4.4.2.3 Undercharging
- Chronic undercharging will lead to extensive sulfation and underperformance. These batteries will be difficult to recharge.

4.4.3 High/Very Low temperature operations

4.4.3.1 Higher temperatures (above 120°F) will lead to quicker grid and active material deterioration.

4.4.3.2 Very low temperature (below -10°F) operations could lead to chronically undercharged batteries

4.4.4 Improper electrolyte level adjustments

4.4.4.1 Adding contaminated water/other liquids

- Electrolyte must be free from organics, chlorides and metals. These impurities will affect performance significantly.

4.4.4.2 Using a battery with low levels of electrolyte

- A battery operated with low levels of electrolyte will only use the submerged portions of the battery plates, causing irreversible damage to the exposed portion of the plates.

4.4.4.3 Adding too much water in some cells

- These cells will have electrolyte that could be considerably diluted, affecting the essential chemical balance in the cell, causing decrease in performance.

**Table 2
RECOMMENDED VOLTAGE REGULATOR SETTINGS**

Operating Temperature (°F)	12 Volt Battery			24 Volt Battery		
	Minimum	Nominal	Maximum	Minimum	Nominal	Maximum
120	13.35	13.75	13.95	27.1	27.5	27.8
90	13.6	14.0	14.2	27.6	28.0	28.3
60	13.85	14.25	14.45	28.1	28.5	28.8
30	14.1	14.5	14.7	28.6	29.0	29.3
< 0	14.35	14.75	14.95	29.1	29.5	29.8

CONTINUOUS OPERATION ABOVE 120°F IS NOT RECOMMENDED

Premium Aircraft Batteries
 TELEDYNE BATTERY PRODUCTS
 www.gillbatteries.com
 800.456.0070



Gill DRY-CHARGE MAINTENANCE MANUAL

PREPARING DRY-CHARGED BATTERIES FOR USE

5.1 TOOLS NEEDED

- a) Hydrometer (To read 1.110 to 1.300), with zero at 80°F.
- b) 80°F Correction Thermometer; a thermometer capable of reading up to 150°F may also be used.
- c) Constant-Current Charger.
- d) Wax-coated funnel (provided); a plastic (non-nylon) funnel may also be used.

5.2 FILLING (OR ACTIVATION)

- 5.2.1 Always use the electrolyte that is supplied with the batteries. For design performance, do not use electrolyte with specific gravities other than those specified.
- 5.2.2 Please refer to Activation and Service Instructions for Gill Dry-Charged Lead-Acid Aircraft Batteries, TBP 1560, latest revision provided with your battery.
- 5.2.3 If electrolyte is not available, refer to Appendix C for preparation of electrolyte from concentrated acid.

WARNING

Electrolyte contains sulfuric acid which is highly corrosive and can cause severe burns to exposed skin and permanent damage to eyes. Avoid spilling or splashing. Wear rubber gloves and safety goggles whenever you are handling electrolyte or examining batteries during charging.

- 5.2.4 The activation process:
 - a) Inspect the battery for any shipping damage prior to filling.
 - b) Permanently mark the activation date (Month and Year) on the battery, making sure that the battery is not damaged while doing so.
 - c) Remove storage caps.
 - d) Make sure you have enough electrolyte - refer to Table 3.



Gill DRY-CHARGE MAINTENANCE MANUAL

- e) Gently shake the electrolyte bottles **before** removing the cap to ensure electrolyte is thoroughly mixed.

CAUTION

When adding electrolyte to dry charged batteries, ensure cleanliness at all times. Electrolyte contains about 40% sulfuric acid and is very corrosive. Metals, chlorides or organic impurities in electrolyte will definitely impair performance. Avoid contaminating the electrolyte. Any plastic container except nylon may be used to contain the electrolyte.

- f) Carefully add electrolyte through the wax-coated funnel (provided) or a plastic (non-nylon) funnel - to prevent spillage, filling each cell to the top of the separators

WARNING

Wear safety goggles when looking into the cells and acid resistant gloves when handling batteries. Electrolyte contains sulfuric acid, which is highly corrosive and can cause severe burns to exposed skin and permanent damage to eyes.

- g) Install the vent caps with a quarter turn and let the battery sit for approximately 30 minutes (soak time) - gently rock the battery a few times to allow the entrapped air to escape.
- h) The battery may heat up due to the reactions going on in the cells, occasionally causing the electrolyte to react vigorously. Please ensure vent caps are placed on correctly. Use external cooling (fan) if needed.
- i) After the soak time, check each cell for electrolyte levels. Add electrolyte to the top of the separators. **DO NOT ADD ANY WATER AT THIS TIME.**
- j) Connect the charging cables and begin charging using our recommended methods (Refer to Initial Charging Rates in Table 4).
- k) After the first hour of charge, check the electrolyte level in each cell. Make sure that the level is just to the bottom of the split ring. **USE ELECTROLYTE ONLY.**
- l) Replace vent caps finger tight, to ensure electrolyte does not leak.



Gill DRY-CHARGE MAINTENANCE MANUAL

- m) Make sure that battery temperature does not exceed 115°F. Reduce the charge rate or use external cooling if it does.
- n) Completion of charge is indicated by a stable specific gravity reading of 1.275 to 1.295 (temperature compensated as described in Appendix B) taken in three readings over three hours, as described in paragraph 5.2.5, Initial Charging Instructions. Use recommended hydrometer.

A stable on-charge voltage reading may also be used. The battery should typically be charged in about 8–12 hours using a constant current charger.

- o) At the end of charge, all cells should be gassing (bubbling) uniformly.
- p) After the battery is fully charged, adjust the level of the electrolyte to the bottom of the split ring (bottom of vent well) with the charger still on.

Figure 2

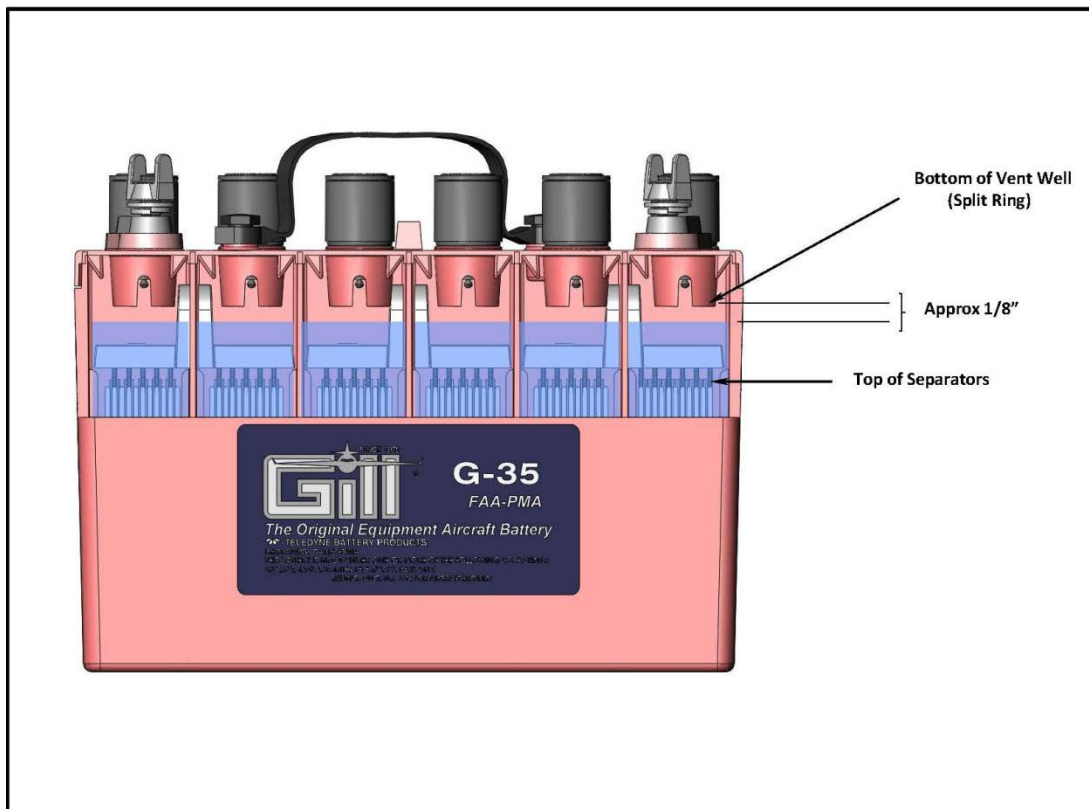

Premium Aircraft Batteries
TELEDYNE BATTERY PRODUCTS
www.gillbatteries.com
800.456.0070



Gill DRY-CHARGE MAINTENANCE MANUAL

**Table 3
ELECTROLYTE VOLUMES**

Gill Part Number	Former Part Number	Fill Volume (Quarts)	Gill Part Number	Former Part Number	Fill Volume (Quarts)
G-25	PS6-9	2	G-247	PS12-24P11M	4
G-35	PS6-11	3	GE-50E	MS18045-42	8
G-35M	-----	3	GE-50C	AN3150	8
G-88	6GAA-13	8	GE-51E	MS18045-41	5
G-240	PS12-9	3	GE-51C	AN3151	5
G-241	PS12-9M	3	GE-54C	AN3154	3
G-242	PS12-11	3	G-638E/C	BB638/T-E	9
G-243	PS12-11M	3	G-6381E/C	BB638/T1-E	9
G-244	PS12-24P9	4	G-639E/C	BB639/T-E	5
G-245	PS12-24P9M	4	G-640E	BB640/T-E	3
G-246	PS12-24P11	4	G-641	G-41	4

Note: These are approximate volumes.

5.2.5 INITIAL CHARGING INSTRUCTIONS

- a) Replace vent caps tightly and start charging per recommendations for your battery type. Note Table 4 for Initial Charge Rates.
- b) Do not allow the battery to stand for more than 8 hours, after the electrolyte has been added and before you begin to charge.
- c) After the first hour of charge, check the electrolyte levels in each cell. Make sure that the level is just to the bottom of the split ring. Use hydrometer to remove excess. If the electrolyte levels are low, **ADD ELECTROLYTE ONLY. DO NOT ADD WATER AT THIS STAGE.**

WARNING

Wear safety goggles when looking into the cells and acid resistant gloves when handling batteries. Electrolyte contains sulfuric acid, which is highly corrosive and can cause severe burns to exposed skin and permanent damage to eyes.

Premium Aircraft Batteries
TELEDYNE BATTERY PRODUCTS
www.gillbatteries.com
800.456.0070



Gill DRY-CHARGE MAINTENANCE MANUAL

- d) Replace the vent caps tightly then clean up any spilled electrolyte.
- e) Maintain temperature of the battery around 75°F to 110°F. If it gets hotter, reduce the charging rates and increase the charge time proportionally. Note: The charge time can be adjusted proportionally to compensate for chargers that may not be capable of delivering the recommended rate.
- f) It may take 8 to 12 hours to fully charge the battery using a constant current charger.
- g) The best indicator of full charge is a stable specific gravity reading. Using the recommended hydrometer, take three readings at approximately equal time intervals over three hours. When fully charged, the specific gravity should be around 1.275 to 1.295. Make sure that the readings are temperature compensated as described in Appendix B.

Appendix B has appropriate measurement techniques using a hydrometer. Please call Teledyne Battery Products if there are any further questions.

- h) If it is not possible to measure specific gravity, battery voltage may be used as an indicator. ON-CHARGE battery voltages will stabilize around 32 volts when charging at constant current for 24 volt batteries or around 16 volts for 12 volt batteries.
- i) At the end of charge, all cells will be gassing freely and the battery voltage will stabilize and start to drop slightly. At this point, the current rate must be switched to the "Final Charge Current" – as indicated in Table 4.

WARNING

Electrolyte contains sulfuric acid which is highly corrosive and can cause severe burns to exposed skin and permanent damage to eyes. Avoid spilling or splashing. Wear rubber gloves and safety goggles whenever you are handling electrolyte or examining batteries during charging.

- j) Once the battery has been charged and all cables disconnected, clean residual electrolyte on the battery as follows: Make sure the vent caps are on tight – otherwise the solution of baking soda will enter the cells and partly neutralize the electrolyte – then clean the battery with water and baking soda. Wipe dry before installation.



Gill DRY-CHARGE MAINTENANCE MANUAL

**Table 4
INITIAL CONSTANT CURRENT CHARGE RATES**

Gill Part Number	Former Part Number	Initial Charge Current (A)	Final Charge Current (A)
G-25	PS6-9	3	1.5
G-35	PS6-11	3	1.5
G-35M	-----	3	1.5
G-88	6GAA-13	6	3
G-240	PS12-9	2	1
G-241	PS12-9M	2	1
G-242	PS12-11	3	1.5
G-243	PS12-11M	3	1.5
G-244	PS12-24P9	3	1.5
G-245	PS12-24P9M	3	1.5
G-246	PS12-24P11	3	1.5
G-247	PS12-24P11M	3	1.5
GE-50E	MS18045-42	3	1.5
GE-50C	AN3150	3	1.5
GE-51E	MS18045-41	3	1.5
GE-54C	AN3154	2	1
GE-51C	AN3151	3	1.5
G-638E	BB638/T-E	3.5	2.5
G-6381E	BB638/T1-E	3.5	2.5
G-639E	BB639/T-E	3	1.5
G-640E	BB640/T-E	3	1.5
G-641	G-41	3	1.5

Note: The Final Charge Current is initiated once the cells start gassing.

Premium Aircraft Batteries
 TELEDYNE BATTERY PRODUCTS
 www.gilbatteries.com
 800.456.0070



Gill DRY-CHARGE MAINTENANCE MANUAL

INSTALLATION

WARNING

When installing or removing a battery, take special care to ensure that no sparks are created by tools, and that the terminals are not shorted out by tools or loose jewelry. **ALWAYS REMOVE THE GROUND CABLE FIRST AND INSTALL IT LAST. IF POSSIBLE, ATTACH THE GROUND CABLE TO THE FRAME OF THE BATTERY COMPARTMENT.** Do not lift the battery by their vent tubes, receptacles or terminals.

6.1 BATTERY INSTALLATION PRE-VERIFICATION

If the original equipment battery is of another type or manufacture, the Teledyne Gill replacement should be accomplished with the proper FAA Approved Supplemental Type Certificated installation kit.

WARNING

The battery compartment must be coated with an acid resistant material to prevent corrosion due to accidental spills of electrolyte. If possible, the spilled electrolyte must be drained away from or contained such that it does not come into contact with the aircraft systems or structure.

WARNING

BATTERIES MUST NOT BE LOCATED IN ENGINE COMPARTMENTS UNLESS ADEQUATE MEASURES ARE TAKEN TO GUARD AGAINST POSSIBLE FIRE HAZARDS, DELETERIOUS EFFECTS OF HIGH TEMPERATURE ON BATTERIES AND PROVISION FOR ADEQUATE VENTILATION AROUND THE BATTERY.

WARNING

Aircraft must be equipped with a leak proof battery ventilation system. The system provides for the removal of gases and acid fumes from the airplane in order to reduce fire hazard and to eliminate corrosion of metal parts due to acid.

6.2 BATTERY VENTILATION

Some Teledyne Gill batteries are designed with cover manifold vents (single or double) so air can flow over the top of the battery and through a sump jar, where the fumes are neutralized by a sodium bicarbonate solution or dry sodium bicarbonate.



6.3 SUMP JAR TREATMENT

The sump jar has a capacity of approximately one pint and is available through your Teledyne Gill battery distributor. The jar should contain a 1/2" thick pad saturated with a 5% solution of sodium bicarbonate in water or about 3/8" of dry sodium bicarbonate. The tube carrying fumes to the sump extends into the jar about 1" from the lid. See Figure 3 for basic ventilation outline.

6.4 VENTILATION SYSTEM REQUIREMENTS

An overboard discharge tube leads from the top of the jar to a point outside the aircraft. The tube is designed so there is air flow from the inlet venting out of the plane (with negative pressure at inlet) whenever the aircraft is in flight. This helps to ensure a continuous flow of air across the top of the battery, through the sump and outside the aircraft. See FAA AC 43.13-1B, Chapter 11, Section 2, Battery Ventilating Systems.

Figure 3
Battery Ventilation System

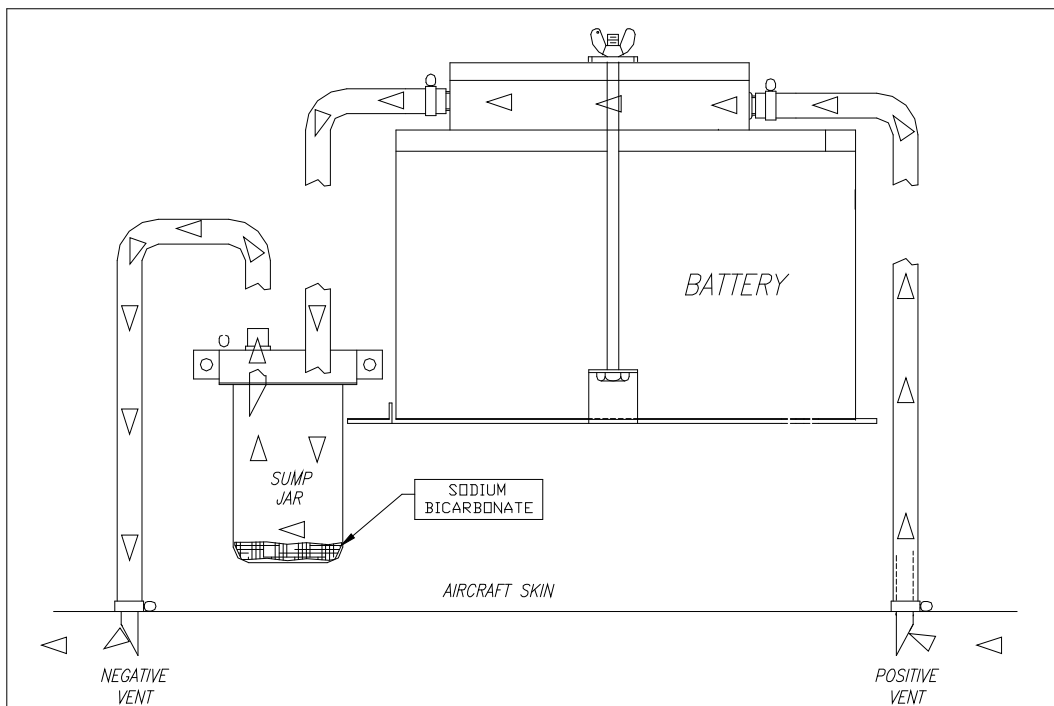



Gill DRY-CHARGE MAINTENANCE MANUAL

SERVICING

7.1 SERVICE REQUIREMENTS

- 7.1.1 Proper maintenance is essential if the battery is to achieve maximum life and performance. To assure these goals, periodic inspection in the aircraft is necessary. Please review the latest revision of Activation and Service Instructions for Gill Dry-Charged Lead-Acid Aircraft Batteries, TBP 1560.
- 7.1.2 To ensure continued airworthiness, remove the battery from the aircraft and perform capacity test (5.1.4) initially at 800 +/- 50 flight hours or 11 +/- 1 calendar month(s) whichever comes first. After the initial check perform the capacity test at 400 +/- 50 flight hours or 6 +/- 1 calendar month(s) whichever comes first.
- 7.1.3 For continuing limited (less than one hour) flying, the battery should be removed from the aircraft at least once a month for top-off charging. The Constant Voltage charging method described in the Activation and Service Instructions must be used.
- 7.1.4 The use of separate lead-acid and nickel-cadmium battery storage facilities are recommended to prevent electrolyte contamination.

7.2 CONNECTOR/WIRING INSPECTION

- 7.2.1 If the aircraft is equipped with a battery quick disconnect, the mechanical integrity of the plug(s) must be checked for fit on the attaching screw to receptacle bayonet pins. The resiliency of the female mating surfaces to the battery receptacle terminals must also be checked.
- 7.2.2 Early discovery of defective connectors as well as battery receptacles is extremely important to prevent failure or possible fire hazard.

Check for the following:

- a) Excessively loose handle and locking assembly.
- b) Pitted or corroded mating surfaces.
- c) Burn marks caused when battery is disconnected under load.



Gill DRY-CHARGE MAINTENANCE MANUAL

- d) To test for the resiliency of the mating surfaces to an oversized pin, insert the larger diameter probe of the tool, TBP 3600-51 Rev A, or newer (GO-NOGO Gauge), into each helix or sleeve to maximum depth. The fit should be snug and require a removal force greater than one pound.
- e) To be assured that the contact is adequate for a worn battery pin, insert the small diameter end of the tool. This must also provide a snug fit, with a nominal removal force greater than one pound.

Replace the connector if it shows excessive wear or fails to meet the fit test.

- f) Battery contact pin must be inspected for corrosion, pitting or burn marks. If any of these defects exist, the surfaces should be cleaned.
- g) If the cleaning process reduces the pin diameter below 0.370", the battery must be replaced.

7.2.3 In addition to inspecting the connector, condition and type of wiring must be examined. Excessive corrosion and use of aluminum wire can be detrimental to safe operation. Please clean/replace wiring. Replacement wiring kits are available from the aircraft manufacturer.

7.3 ELECTROLYTE LEVELS

7.3.1 Electrolyte levels must be maintained just over the plates at all times. Lower levels will damage the battery. Replenish electrolyte with clean water (preferably distilled), and NOT electrolyte, unless electrolyte has been inadvertently spilled from the battery. See Figure 2 for levels.

The frequency of water additions will depend on:

- a) Battery duty cycle
- b) Battery operating temperature
- c) Generator voltage regulator setting
- d) Flight hours

7.3.2 Charge the battery when water is added. This will mix the electrolyte and water to provide a homogeneous electrolyte. Continue charging until the voltage and specific gravity readings are constant over three readings taken over three hours at approximately equal intervals.



Gill DRY-CHARGE MAINTENANCE MANUAL

WARNING

Electrolyte contains sulfuric acid which is highly corrosive and can cause severe burns to exposed skin and permanent damage to eyes. Avoid spilling or splashing. Wear rubber gloves and safety goggles whenever you are handling electrolyte or examining batteries during charging.

- 7.3.3 Adjust electrolyte level (just below the vent well) at *the end* of the charge, with the use of a hydrometer. Remember, the electrolyte will heat-up and expand as the battery is being charged.
- 7.3.4 Check the battery electrolyte level and the sump jar on a routine basis (every 100 flight hours). Do not allow the cells to run dry or be too full of electrolyte.
- 7.3.5 Formation of whitish-green deposits around terminals indicates a leakage of electrolyte. Make sure that all vent caps are tight, clean the deposits with a wire brush and carefully neutralize the terminals with a 5% solution of sodium bicarbonate in water.

WARNING

Electrolyte contains sulfuric acid which is highly corrosive and can cause severe burns to exposed skin and permanent damage to eyes. Avoid spilling or splashing. Wear rubber gloves and safety goggles whenever you are handling electrolyte.

- 7.3.6 The surface of the battery should be wiped clean and kept this way. A film of electrolyte over the top of the battery may bridge across the terminals causing the battery to discharge.
- 7.3.7 If the electrolyte is heavily discolored (brown or black), it represents an aged battery or one that has been subjected to severe vibration or overcharge. Replace the battery.

Note: Excess electrolyte can be stored indefinitely in the containers they were shipped in. Keep the caps on tightly to avoid spillage.



Gill DRY-CHARGE MAINTENANCE MANUAL

7.4 SUMP JAR MAINTENANCE

- 7.4.1 Inspect the electrolyte levels and the sump jar at the specified battery maintenance intervals (noted in 7.3.4).
- 7.4.2 If there is any flow of electrolyte in the sump jar, clean as follows:
- Wear goggles and rubber gloves.
 - Slowly add sodium bicarbonate to the residual acid in the sump jar until the reaction subsides (shake jar side to side, slowly).
 - Wash jar and pad thoroughly.
- 7.4.3 Once the jar has been cleaned, recharge it with fresh sodium bicarbonate as follows:
- Add about $\frac{3}{8}$ " of dry sodium bicarbonate in the jar.
 - Saturate a new pad with a 5% solution of sodium bicarbonate and place pad over the sodium bicarbonate in the jar.
 - Install jar to lid; hand tighten (be sure gasket is in place).

7.5 MANAGING PERIODS OF NON-USE

- 7.5.1 Periodically, users will find that they have to curtail flying for any number of reasons. During these times, the batteries have to be correctly maintained for continued service.
- 7.5.2 Teledyne Battery Products recommends that the battery be removed from the plane during such non-use and maintained using any of the following methods.
- Recharge every 90 days – followed by a recharge per item c below, if needed.
 - Kept on trickle charge (13.5V to 13.8V for 12V batteries, or 27V to 27.6V for 24V batteries)
 - Recharge prior to flight. The recharge should be in accordance with Section 7.8. Alternatively, the Activation and Service Instructions (TBP-1560) can also be used for steps on recharging.

7.6 SHELF LIFE AND STORAGE CONDITIONS

- 7.6.1 Once activated with electrolyte, the battery is constantly undergoing parasitic discharging which vary with types of battery chemistries.



Gill DRY-CHARGE MAINTENANCE MANUAL

Note Figure 4, Shelf Life of Flooded Products.

7.6.2 A battery should not be allowed to remain in a discharged condition for any appreciable period of time. If the battery is kept in such a state, the active material will gradually discharge and convert to lead sulfate and, over time, become very difficult to convert to the original active material.

For every 18°F increase in temperature, the discharge rate will double! If the battery is severely discharged (typically down to ~1.9V/cell), it will sustain permanent damage!

7.6.3 A simple example to illustrate the magnitude of a parasitic drain over time:

If the external load is: 0.1A
And non-use period is: 3 weeks
Total discharge = 0.1A x 3 weeks x 24 hours/day x 7 days/week
= 50.4 Ah

Comparing this loss to the capacity of the battery, this small drain can be quite significant over time!

Figure 4

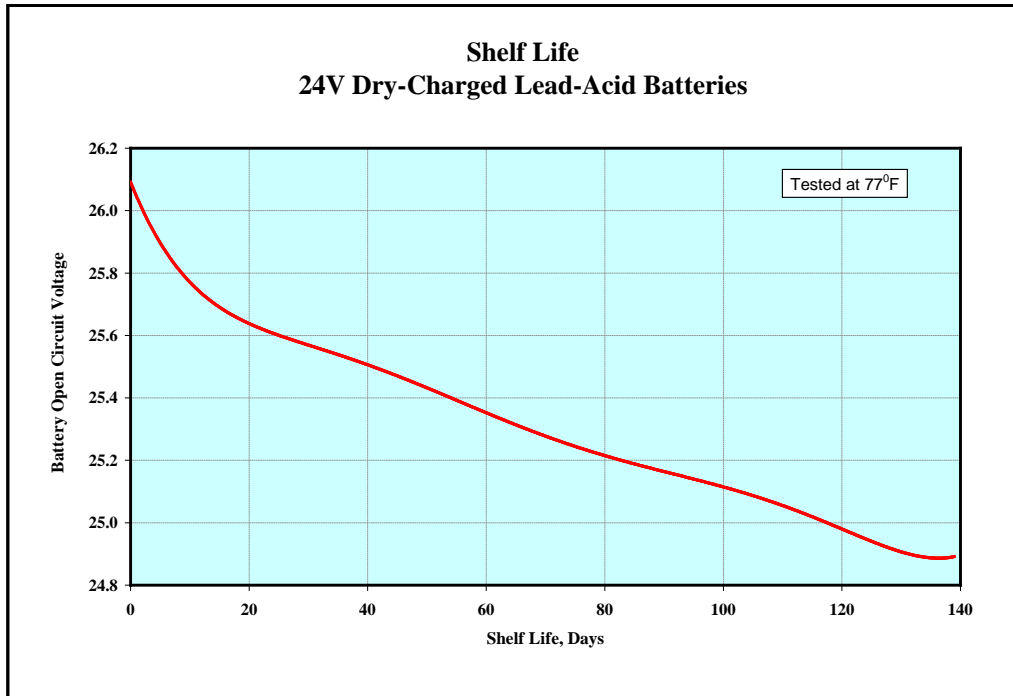



Gill DRY-CHARGE MAINTENANCE MANUAL

7.7 CONTINUED AIRWORTHINESS DETERMINATION FOR GILL AIRCRAFT BATTERIES

7.7.1 To ensure continued airworthiness remove the battery and perform capacity test, as noted below, initially at 800 ± 50 flight hours or 11 ± 1 calendar month(s) whichever comes first. After the initial service, perform the capacity test at 400 ± 25 flight hours or 6 ± 1 calendar month(s), whichever comes first.

The capacity test shall be performed as follows:

- a) Check for proper battery installation per STC Installation Instructions when performing annual and 100 hour inspections and when replacing battery after capacity test.
- b) Remove the battery from the aircraft and charge it according to Teledyne Battery Products' recommended charging instructions. Allow the battery to stand on open circuit for one hour.
- c) Connect the fully charged battery to a capacity tester that incorporates a load resistance, amp meter, volt meter and a timer.
- d) Discharge the battery at the one hour capacity rate to 1.67 volts per cell (10 volts for a 12 volt battery and 20 volts for a 24 volt battery). Record the discharge time.
- e) The battery is considered airworthy if it meets 80% of the one hour capacity rating (48 minutes to the cut-off voltage).
- f) If the battery fails to meet the minimum run-time, recharge using the constant current method until the specific gravity reading stabilizes over three consecutive readings. Allow the battery to stand on open circuit for one hour.

WARNING

Electrolyte contains sulfuric acid which is highly corrosive and can cause severe burns to exposed skin and permanent damage to eyes. Avoid spilling or splashing. Wear rubber gloves and safety goggles whenever you are handling electrolyte.



Gill DRY-CHARGE MAINTENANCE MANUAL

- g) Repeat the discharge test as indicated. If the failure persists, replace the battery.
- h) If the battery is found to be airworthy, **it must be recharged** prior to re-installing it in the aircraft.

7.7.2 The continued airworthiness instructions noted in 7.7.1 are recommended, unless mandated in TC/STC or other design approval.

7.7.3 Proper installation, charging and other maintenance records must be kept, in case they are required for warranty adjustments.

7.8 CHARGING

7.8.1 Charging must be conducted in a well-ventilated area at ambient conditions ranging from 65°F to 80°F. Please review charging method (constant-current or constant-voltage) before commencing. The preferred method is constant-voltage for batteries that have already been activated.

WARNING

If the battery room is air-conditioned as part of a general building-wide air conditioning system, the exhaust air from the battery room should not be returned to the air distribution system. The room should have its own exhaust system that vents directly outdoors.

Sufficient ventilation should be provided to prevent hydrogen gas build-up. Please make sure that there are no sources of sparks in the battery room.

7.8.2 Personal safety is of prime importance. Follow manufacturer's instruction at all times. Note the safety precautions at the end of this section.

WARNING

THE NATIONAL ELECTRIC CODE FORBIDS CHARGING BATTERIES INSTALLED IN AIRCRAFT OR WITHIN 10 FEET OF FUEL TANK AREAS.

7.8.3 Correct charging is very important and will affect the overall life of the battery. The charging process is not 100% efficient due to losses resulting from internal



Gill DRY-CHARGE MAINTENANCE MANUAL

resistance and will typically be 10% to 20% higher than the amount of capacity removed during discharge.

7.8.4 Undercharging a battery occurs when the required 105% to 115% of the removed capacity is not returned during recharge. If this were to occur repeatedly, residual lead sulfate will eventually increase in the plates, making it very difficult to recover the battery. In this case the battery will suffer a permanent loss of capacity.

7.8.5 Overcharging generally occurs when constant current charging is used without adequate controls. This is the main reason for the preference of constant voltage charging over constant current. Overcharging a battery will corrode the positive grids and break the water component, in the electrolyte, down to hydrogen and oxygen (electrolysis).

7.8.6 Prolonged overcharging will lead to loss of water from the electrolyte and grid corrosion.

7.8.7 CONSTANT-CURRENT (CI)

7.8.7.1 These chargers must be capable of providing an output of around 33-35 volts and about 4-8 amperes (with selector switch) and provide a timer that can terminate charging when the charge is completed.

7.8.7.2 The ampere hours of energy restored is the product of rate of charge (in amperes) and the time (in hours).

7.8.7.3 Since these chargers are designed to provide a constant current throughout the charging period, this method could lead to overcharging if not controlled. In order to control the charge input, these chargers must have a shut-off timer.

On-charge voltage could go as high as 33 volts (for a 24 volt battery) or 16.5 volts (for a 12 volt battery) as the battery approaches full charge. As long as the charger timing is adequately controlled, this charging regime will not damage the battery.



Gill DRY-CHARGE MAINTENANCE MANUAL

WARNING

Electrolyte contains sulfuric acid which is highly corrosive and can cause severe burns to exposed skin and permanent damage to eyes. Avoid spilling or splashing. Wear rubber gloves and safety goggles whenever you are handling electrolyte.

- 7.8.7.4 Electrolyte specific gravity should be measured and constant over three consecutive readings (see 5.2.5 (g)) or a stable battery voltage (battery voltage should be the same as the charger output voltage over three hours) could be used. Avoid prolonged charging at this voltage.
- 7.8.7.5 It is preferred to use low rates (0.5 – 5 amps) when charging batteries using this technique, in order to reduce heat and minimize corrosion. Note example under “Recharging Deeply Discharged Batteries” for general outline on using constant current recharge.
- 7.8.7.6 Review Figure 5 for a basic charging profile of charge current and battery voltage.

7.8.8 CONSTANT-VOLTAGE (CV)

- 7.8.8.1 These chargers are generally designed to provide a constant voltage source, with selectable initial current rates. Model variants may provide selectable charge voltage. Higher output current will reduce recharge time.
- 7.8.8.2 The current in any circuit is directly proportional to voltage gradient in that circuit (Ohm’s Law). Using CV charging will result in a high initial charging current which will start dropping off when the voltage gradient between the charger and battery begins to decrease.
- 7.8.8.3 Typically, the charger will regulate to 28.4 volts (24 volt batteries) or 14.2 volts (12 volt batteries). As the battery approaches the charger output voltage, charge current will drop below 1 ampere. Please call Gill Technical Support for any additional concerns with charging (see Fig. 5 for typical charge profile).



Figure 5

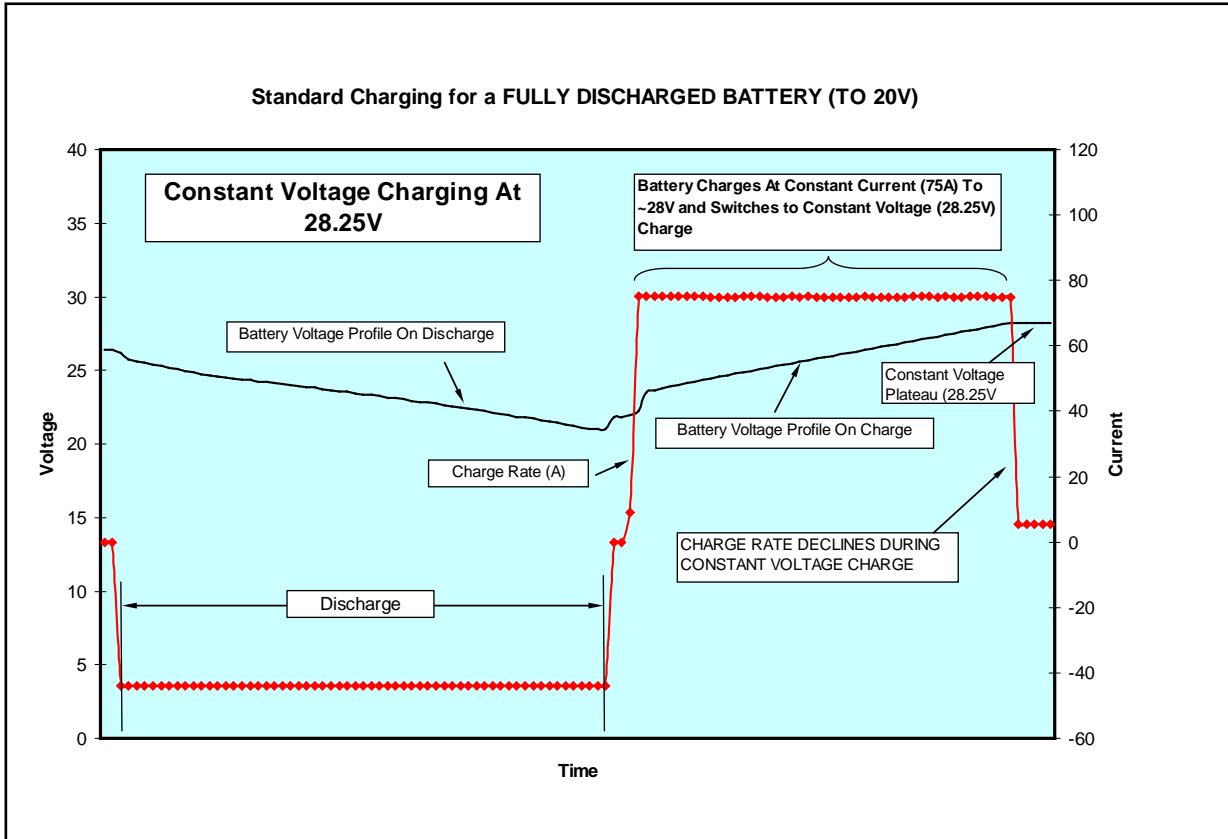

7.9 RECHARGING DEEPLY DISCHARGED BATTERIES

7.9.1 Deep discharge is usually indicated by a battery voltage of less than 10 volts (12 volt battery) or 20 volts (24 volt battery). There is a possibility of recovering these batteries using constant-current charging techniques, provided they have not been in the deep-discharge state for more than 15 days at temperatures around 30°F to 80°F, in which case, the batteries should be replaced.

7.9.2 The battery must be charged at a rate of 1.0A for a total input (in ampere-hours) up to 200% of the one-hour capacity, which is determined as follows:

e.g. for a one-hour capacity of 20 Ah, the time is determined to be:

$2 \times 20 \text{ Ah} = 40 \text{ Ah}$ (Ampere-hours) needed

At the charge rate of 1.0 amperes, the total time would be:

$40 \text{ Ah} / 1.0\text{A} = 40 \text{ hours}$



Gill DRY-CHARGE MAINTENANCE MANUAL

- 7.9.3 Stable voltage, measured 4 hours after charge termination, should be over 26.3V for 24V batteries and 13.1V for 12V batteries. If not, charging should be resumed using guidelines in 7.8.
- 7.9.4 Avoid subjecting a battery to frequent deep discharge, as this could affect the useful life of the battery.

7.10 BATTERY SAFETY

7.10.1 Handling Battery Electrolyte

WARNING
WHEN WORKING WITH ELECTROLYTE, ALWAYS WEAR SAFETY GOGGLES AND PROTECTIVE GLOVES AND CLOTHING. USE EXTREME CARE TO AVOID SPILLING OR SPLASHING ELECTROLYTE (~40% SULFURIC ACID) AS IT IS VERY CORROSIVE AND WILL DESTROY CLOTHING, BURN SKIN AND PERMANENTLY DAMAGE EYES.

- a) When handling plastic-cased batteries, do not exert pressure on the end walls as this could cause the electrolyte to spill out of the vent caps. Use the battery lifting strap or with hands placed at opposite corners.

Electrolyte can be stored indefinitely. BEFORE opening and using the electrolyte, shake the container gently.

EMERGENCY PROCEDURE FOR EXPOSURE TO ELECTROLYTE

If electrolyte is splashed on the body, wash it off immediately using large amounts of cool tap water, or if it spilled out, neutralize it with sodium bicarbonate solution followed by a clean water rinse.

Electrolyte splashed into eyes is extremely hazardous. If this should happen, force the eye open and flush it with cool, clean water for about five minutes or longer if irritation persists. A doctor should be called immediately and appropriate medical care should be applied. Do not add any eye drops or other medication unless told to do so by the doctor.

If electrolyte is taken internally, drink large quantities of water or milk, followed with milk of magnesia, beaten egg whites or vegetable oil. See a doctor immediately.

- 7.10.2 Maintain a safe charging area. Always follow these safety precautions when handling batteries:



Gill DRY-CHARGE MAINTENANCE MANUAL

WARNING

ALWAYS WEAR EYE PROTECTION WHEN WORKING WITH BATTERIES. ELECTROLYTE CAN DAMAGE EYES PERMANENTLY

- a) Review all applicable OSHA guidelines for safety precautions (note MSDS in Appendix C).
- b) Keep sparks, flames, burning cigarettes or other ignition sources away at all times.

WARNING

Batteries generate explosive gases and must be handled with care.

- c) Always use insulated tools.
- d) Leave vent caps on while charging, removing them only when verifying electrolyte levels or checking for gassing. This will prevent cells from “bridging” (temporary shorting out between the cells) because electrolyte could well out of the cells if left open.
- e) Follow charger manufacturer’s instructions.
- f) Do not allow any untrained personnel to work on batteries.
- g) Do not “break” live circuits at the terminals of a battery because sparks will occur at the terminals.
- h) Make certain the charger cables are clean and not frayed. A poor connection can cause localized heating leading to terminal damage/melting or possible arcing.
- i) Make sure the room is well ventilated and isolated from the main air-conditioning system. Gases from batteries are explosive and corrosive (due to entrained sulfuric acid in the gases) and must not be allowed to blend in with the main system.
- j) **ALWAYS TURN THE CHARGER OFF BEFORE DISCONNECTING THE BATTERY.**
- k) Do not touch charger leads while the battery is on charge.



Gill *DRY-CHARGE MAINTENANCE MANUAL*

7.11 JUMP STARTING AN ENGINE

7.11.1 Teledyne Gill batteries that have been discharged to the point where their cranking power has been diminished must ***NOT*** be jumped with another power source.

The discharged battery may not be airworthy because it does not have the necessary capacity required to operate the aircraft avionics and electrical system in the event of generator failure.

**Gill DRY-CHARGE MAINTENANCE MANUAL****RECYCLING BATTERIES****8.1 MATERIAL SAFETY DATA SHEETS**

- 8.1.1 They can be downloaded as needed from the Gill website:
www.gillbatteries.com

8.2 RECYCLER LOCATIONS

- 8.2.1 All parts of spent lead-acid batteries are recyclable. Generally, batteries are collected by retailers and wholesalers who send large quantities to battery recyclers for reclamation. Battery recyclers are permitted hazardous waste treatment recycling facilities. If you have just a few batteries you should contact your local battery retailers or wholesalers.

- 8.2.2 The following is a listing of recyclers in California:

GNB, Inc. Resource Recycling Division
2700 South Indiana Street
Los Angeles, CA 90023
(213) 262-1101

RSR Quemetco, Inc.
720 South 7th Avenue
City of Industry, CA 91745
(800)527-9452

- 8.2.3 The California Department of Toxic Substances Control publishes an annual listing of commercial hazardous waste recyclers, which also includes facilities outside of California. A copy of this publication, the "Directory of Industrial Recyclers" may be obtained by calling (916) 324-2423, or writing to the:

California Waste Exchange Resource Recovery Unit
Hazardous Waste Management Program
Department of Toxic Substances Control
P.O. Box 806
Sacramento, CA 95812-0806



Gill DRY-CHARGE MAINTENANCE MANUAL

8.2.4 Nation-wide Recycling:

Most retailers, auto parts stores or service outlets that sell new lead-acid batteries will accept a small number (one or two) of spent lead-acid batteries for recycling. If you have a larger quantity to be recycled, call to verify that your chosen outlet can handle a larger quantity of old batteries.

Even if you live in a state where there is no lead-acid battery recycling law, it's common for battery retailers everywhere in the U.S. to accept used lead-acid batteries from customers. The spent batteries collected by retailers are shipped to EPA licensed and regulated facilities for recycling.

For additional information, please use the following web address to locate nation-wide recycling facilities: www.batterycouncil.org

8.3 INTERNATIONAL RECYCLING RESOURCES

8.3.1 British Battery Manufacturers Association

26 Grosvenor Gardens
London SW1W 0GT
Direct Tel: +44 (0) 207 838 4800
Direct Fax: +44 (0) 207 838 4801

8.3.2 SNAM (Societe Nouvelle d'Affinage des Metaux)

Rue de la Garenne
St Quentin Sallavier
38297 La Verpilliere Cedex
France
Telephone: 00 33 74 945 985
Battery re-processing.

8.3.3 For smaller batteries, you may also contact the Rechargeable Battery Recycling Corporation (RBRC) at <http://www.rbrc.com/> for directions.



Gill DRY-CHARGE MAINTENANCE MANUAL

FREQUENTLY ASKED QUESTIONS

Q: How can I do the load test in compliance with the Continued Airworthiness requirements if I do not have a tester?

It is preferable to perform the load test with an appropriate tester.

A: 1) Teledyne now offers a brand new load tester. The load tester will be available after September 2004. Please contact Teledyne Sales for further information.

2) Aero Quality and Vencon provide affordable battery testers. These companies can be contacted through their web site as follows:

www.aeroquality.com and www.vencon.com

If no tester is available:

3) The battery may be discharged with several components, of known load, on the plane – the total load approximating as closely as possible to the emergency capacity of the battery. Discharge the battery for 30 minutes. The battery voltage should be at or above the minimum required (10V for a 12V battery and 20V for a 24V battery).

For known loads which are not the same as the emergency rate, use the appropriate performance curves for that battery, to determine the expected run-time. The curve below indicates how the axes should be read. Example below indicates that at 30A discharge, the battery will run for 0.7 hours (42 minutes) to the end point voltage.

READING A PERFORMANCE PLOT

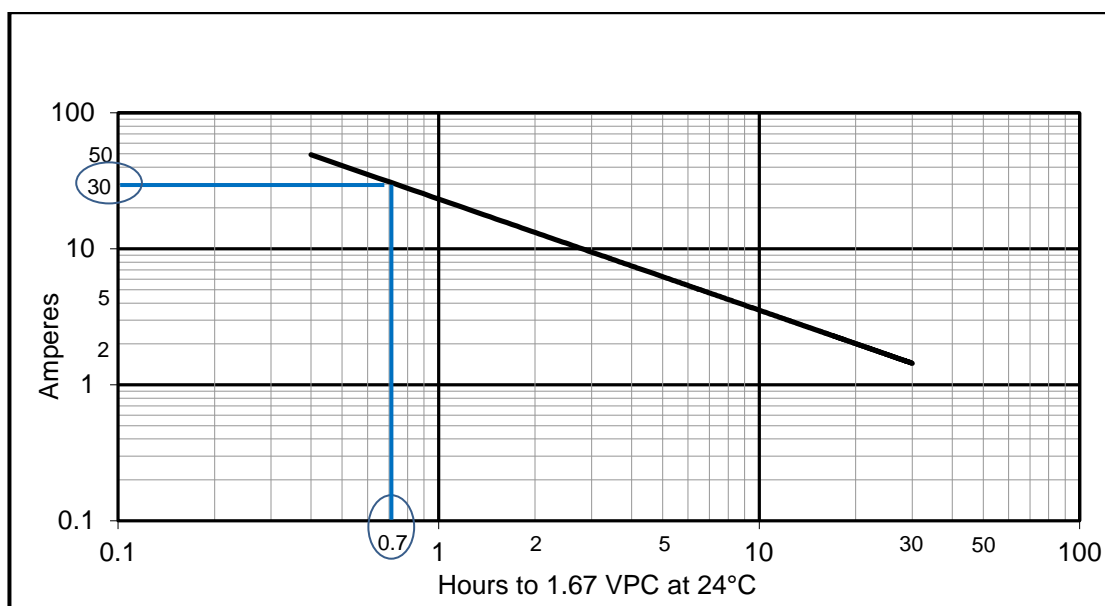



Gill DRY-CHARGE MAINTENANCE MANUAL

Q: How can I determine if a dry charged battery is fully charged without using a hydrometer?

A: Battery voltage will stabilize towards full charge and begin a slight dip. During this time, all cells should be gassing uniformly. At this stage, the battery is considered to be fully charged.

Q: I purchased a dry-charged battery a few months ago and activated it; can I leave it on the shelf until I am ready to use it?

A: Batteries start to age as soon as electrolyte is added. Once the batteries have electrolyte added to them, they must be put in service. If you are unable to do so, condition the batteries every two to three months (top-off charge).

Q: My battery voltage is very low. I filled all the cells with the electrolyte I had received. The electrolyte was not enough, but I topped off the low cells with water. Can you help?

A: During initial conditioning, no water is to be added to the cells. Fill and adjust levels only with electrolyte. Water is only added after the battery has been in service for some time and has lost water due to evaporation. If you do not have enough electrolyte, contact Teledyne Customer Service.

Q: I filled the battery with electrolyte and have been charging the battery on trickle charge for three days. The specific gravities are around 1.245 and battery voltage is 14V. Why is the gravity so low?

A: This is a two part question. The first concern is with the charger. Trickle chargers are constant voltage chargers and will not charge the battery properly. Teledyne recommends constant current charge when the battery is being charged for the first time. Please note our description of constant current charging described in 7.8.7.

Charging MUST be accomplished as Teledyne has recommended. Do not use trickle chargers or constant voltage charging, as these methods are not satisfactory for initial charge.

The other concern is how battery voltage is being measured. Battery voltage must always be measured two to three hours after charging has been stopped. In this case, a measure of 14V indicates that the user was determining battery voltage directly after charging was turned off.



Gill DRY-CHARGE MAINTENANCE MANUAL

Q: Where can I buy a good charger for 12V and 24V products?

A: Teledyne Gill provides two good chargers for 24V products. Our TDMC-90 and the TSC-01V will provide the best charging capabilities. Please review our web site for detailed specifications or call Gill Technical support for additional information.

Q: How do I process my warranty?

A: Teledyne provides a Warranty Card with each battery it sells. The customer should call the Warranty Helpline at (800) 456 0070, ext. 7 or 8 and discuss any warranty issues. After obtaining a warranty authorization number, the customer should send the completed form to any authorized Gill dealer for processing.



Gill DRY-CHARGE MAINTENANCE MANUAL

GLOSSARY

Active material	The formed (charged) material on the positive and negative electrodes (plates)
AGM	Absorptive Glass Mat, a non-woven fiberglass separator that holds the electrolyte.
Ah	Ampere-hour; the standard designation of capacity units for batteries.
Corrosion	Refers to oxidation (generally excessive) of the positive plate.
CFR	Code of Federal Regulations
Electrolyte	The liquid added to a battery that is capable of conducting ions between the two electrodes.
Electrolysis	Decomposition of an electrolyte by the action of an electric current flowing through the electrodes (positive and negative plates).
IATA	International Air Transport Association
ICAO	International Civil Aviation Organization
IEC	International Electro-technical Commission
Ipp	Peak current, in amperes, at 0.3 seconds of a 15 second discharge, while testing at a constant terminal voltage of 12V (for 24V lead acid batteries).
Nonspillable	Refers to the ability of the battery to retain the electrolyte when subjected to tests identified under US DOT Reg 49 CFR, Part 173.159, paragraph "d".
OCV	Open Circuit Voltage; measured with no loads connected to the battery
Passivation	Refers to the oxidation of the negative electrode.
Recombination	The process by which oxygen combines (reacts) with the negative active material
Sponge lead	Fully charged negative plates convert to a very porous pure lead material, often referred as sponge lead since it resembles a sponge under high magnification.
State of Charge	The measure of charge level of a battery. This measure is not the same as available capacity. A "spent" battery could indicate a full state of charge (voltage) but has lower capacity than the battery started out with.
Sulfation	The product of discharge, lead sulfate, formed on both positive and negative plates.
Venting	Means for a battery to release the gases it generates during charging.

Gill DRY-CHARGE MAINTENANCE MANUAL
GILL TROUBLE-SHOOTING GUIDE

PROBLEM	CAUSE	RECOMMENDATIONS
Battery has low capacity	Battery is at end of life.	Replace battery.
Will not come up to full charge.	Charging rate is insufficient.	Check and correct settings for appropriate battery in accordance with guidelines set in these instructions, under SERVICING.
Will not hold charge.	Capacity of battery may be lower than required for application.	Confirm application requirements and replace battery.
	Flight legs too short to charge the battery sufficiently.	Remove the battery from the aircraft and recharge when necessary.
	Standing too long (hot climate).	Remove battery from aircraft, check and replenish electrolyte and recharge.
	Equipment left on accidentally, battery is discharged.	After fully charging battery, continue at reduced rate of one amp or less until charging voltage stabilizes over three hours. Perform a capacity check per Continuous Airworthiness Instructions, page 19. Replace if necessary.
	Short circuit; short to ground in wiring; or other electrical component problem	Check wiring and rest of electrical system. Correct problem; recharge battery.
	Loose connections; corrosion	Clean and neutralize connections; tighten all connections
	Electrolyte on top of cells and battery box - caused by overfilling; high charge rates. Could cause battery to "bridge" across the terminals - discharging battery in the process.	Remove battery from aircraft; clean and neutralize the exterior of the battery and inside battery box with a solution of sodium bicarbonate (baking soda). Wash with clean water and dry thoroughly. Recharge battery before placing in service.
	Quick disconnect worn beyond tolerance.	Check Cannon or Elcon type connectors for good contact (see 7.2) with Teledyne Go-NoGo gauge part number 3600-51.
	Battery could be shorting under load.	The battery could be investigated as follows: i) After a full charge (verified by specific



Gill DRY-CHARGE MAINTENANCE MANUAL

PROBLEM	CAUSE	RECOMMENDATIONS
Will not hold charge (cont'd).		gravities over 1.280), subject the battery to the one hour rate of discharge. Replace battery if it fails to support the load for at least 48 minutes (80% of one-hour capacity); ii) Subject the battery to a short duration (30–90 seconds) of a high rate of discharge (over 150Amps) – measure battery voltage. If the voltage drops below 9V (12V battery) or 18V (24V battery) – replace battery.
	Battery could be self-discharging due to low state of charge. Sulfation can build up – based on repeated undercharge situations.	Fully charge battery, clean the top and place the battery in service. If this repeats, remove the battery from service and monitor the drop in voltage over a week. If it exceeds the rate shown in Figure 3, replace the battery. NOTE: If the electrolyte is contaminated with metals (such as iron) the battery will not hold a charge. Please ensure electrolyte is kept clean at all times.
	Excessive sulfation build-up caused by leaving the battery in a discharged state for an extended period of time.	Charge the battery at a constant current rate of 1 amp for a time equal to 1.5 times the one hour capacity, e.g if the battery is a 10Ah battery, charge at 1A for 1.5 x 10 = 15 hours. Occasionally, one may need to cycle the battery a couple of times (provide a discharge – to the specified end voltage – followed by a charge as identified above). At the end of re-conditioning, specific gravity of the electrolyte must be at 1.275 or better for all cells.
	Possible excessive use of starter and other electrical equipment.	Remove and recharge the battery; reduce equipment load or use an approved higher capacity battery.

Premium Aircraft Batteries
 TELEDYNE BATTERY PRODUCTS
 www.gillbatteries.com
 800.456.0070



Gill DRY-CHARGE MAINTENANCE MANUAL

PROBLEM	CAUSE	RECOMMENDATIONS
Battery life too short.	Application.	<p>Ensure that battery selection is correct for the application.</p> <p>Infrequent flying will lead to gradual discharge of battery, especially if the breaks between flying are over three weeks. Please review directions under Managing Periods of Non-Use under SERVICE.</p> <p>Ensure battery is not subjected to excessive vibration or high temperatures in service.</p>
	Charging variations such as overcharging or chronic undercharging brought about by short flights.	<p>Overcharging could be eliminated by inspecting and correcting charge voltages.</p> <p>Excessive undercharging (very short flights) should be compensated by periodic charging of battery.</p>
	Using the battery with low electrolyte levels.	<p>Electrolyte level must be kept at the required levels.</p> <p>Use clean water – preferably distilled – only.</p>
Case damage	Hold-down loose or too tight	Remove battery and inspect. If no visual damage is noted, charge and perform capacity check. Replace battery if case is damaged.
	<p>Frozen battery due to: Addition of water in cold weather without charging the battery.</p> <p>Low specific gravity caused by improper filling/storing battery in an undercharged condition.</p>	Replace battery.
Electrolyte runs out of vent plugs Or Battery consumes excessive water.	Battery is overfilled	Remove excess electrolyte to specified levels. Ensure specific gravity is correct.

Premium Aircraft Batteries
 TELEDYNE BATTERY PRODUCTS
www.gillbatteries.com
 800.456.0070



Gill DRY-CHARGE MAINTENANCE MANUAL

PROBLEM	CAUSE	RECOMMENDATIONS
Electrolyte runs out of vent plugs Or Battery consumes excessive water (cont'd).	Battery is chronically overcharged	Check voltage regulator settings and adjust as required
Battery voltage is at "0" and will not accept charge.	Shorted or grounded cable causing direct full discharge of battery and irreparable damage.	Repair short or ground in electrical system and replace battery.
Electrolyte in battery freezes.	Battery left in a discharged state. Electrolyte specific gravity too low.	Replace battery.
Polarity reversed	Battery inadvertently charged in reverse.	Replace battery
NEW BATTERY is under capacity or uses excessive water during first 25 hours of use.	Battery may not have received a full initial charge or full complement of electrolyte.	Remove battery from aircraft and charge completely. If possible, provide a few cycles to the battery.

Premium Aircraft Batteries
 TELEDYNE BATTERY PRODUCTS
www.gilbatteries.com
 800.456.0070

**Gill DRY-CHARGE MAINTENANCE MANUAL****APPENDIX A****Battery Specifications and Performance Curves.**

1. G-25
2. G-35
3. G-88
4. G-240
5. G-241
6. G-242
7. G-243
8. G-244
9. G-245
10. G-246
11. G-247
12. G-6381E/C
13. G-639E/C
14. G-638E/C
15. G-640E/C
16. G-641
17. GE-50E/C
18. GE-51E/C
19. GE-54E/C



Gill DRY-CHARGE MAINTENANCE MANUAL

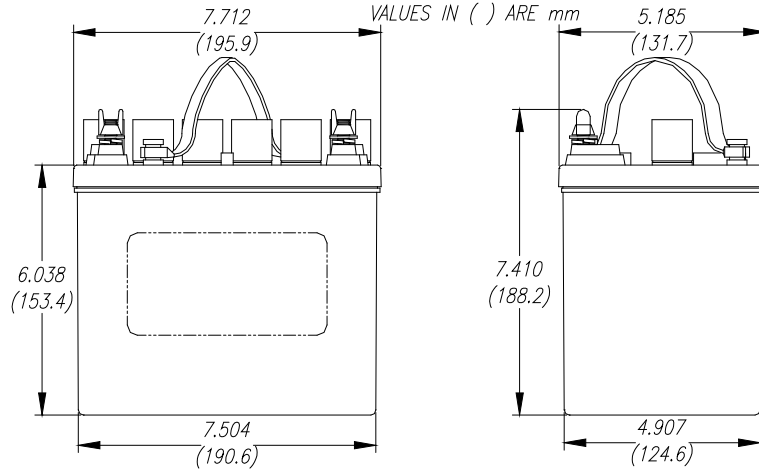

G-25 Performance Data

Run time	End Volts Per Cell	Test Temperature (°C)	Watts	Amps	Capacity (Ah)	Energy (Wh)	Weight (lb)	Electrolyte Volume (quarts)
60 sec	1.2	-18	2,700	225	3.75	45	21.3	2
30 min.	1.67	24	360	30	15	180		
60 min.			216	18	18	216		
20 hr.			18	1.5	30	360		

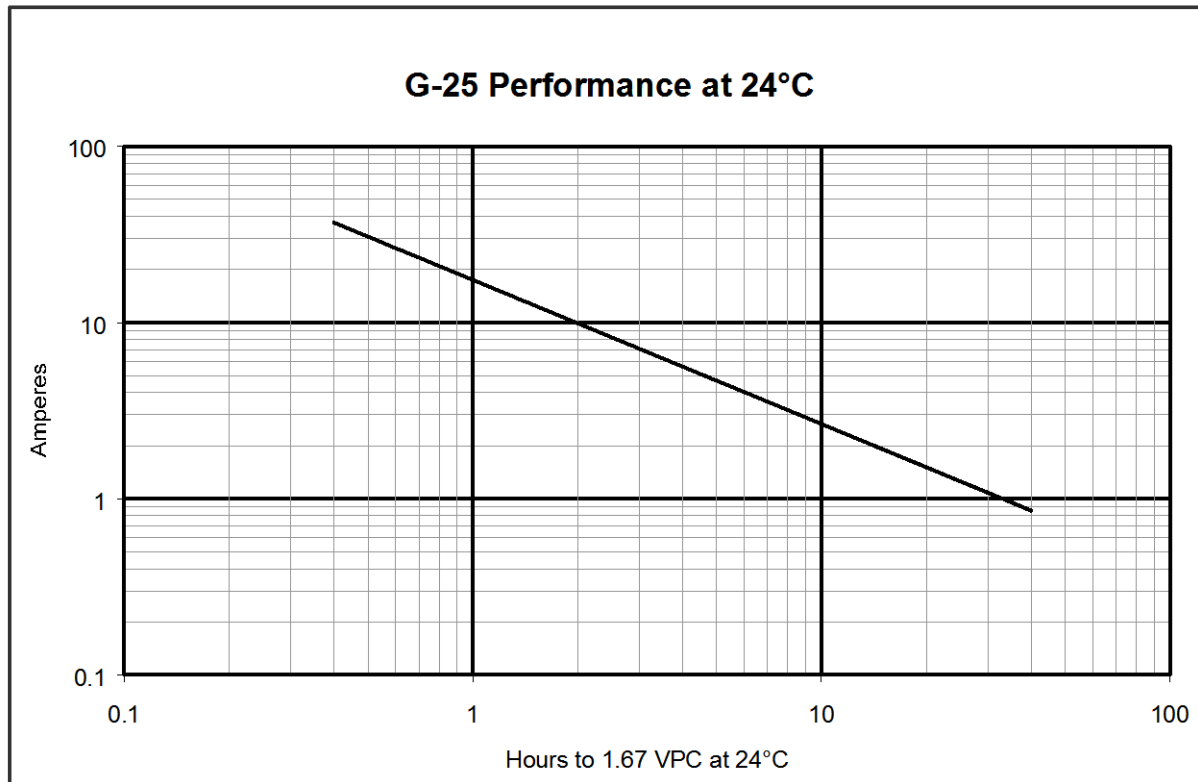



Gill DRY-CHARGE MAINTENANCE MANUAL

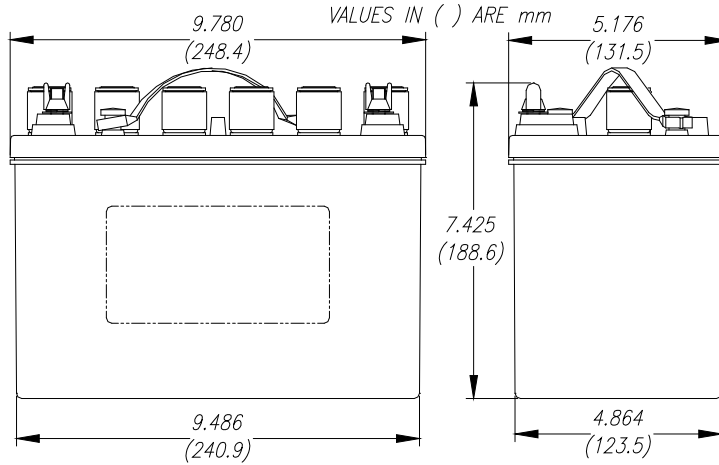

G-35 Performance Data

Run time	End Volts Per Cell	Test Temperature (°C)	Watts	Amps	Capacity (Ah)	Energy (Wh)	Weight (lb)	Electrolyte Volume (quarts)
60 sec	1.2	-18	3,900	325	5	65	27	3
30 min.	1.67	24	480	40	20	240		
60 min.			276	23	23	276		
20 hr.			23	1.9	38	456		

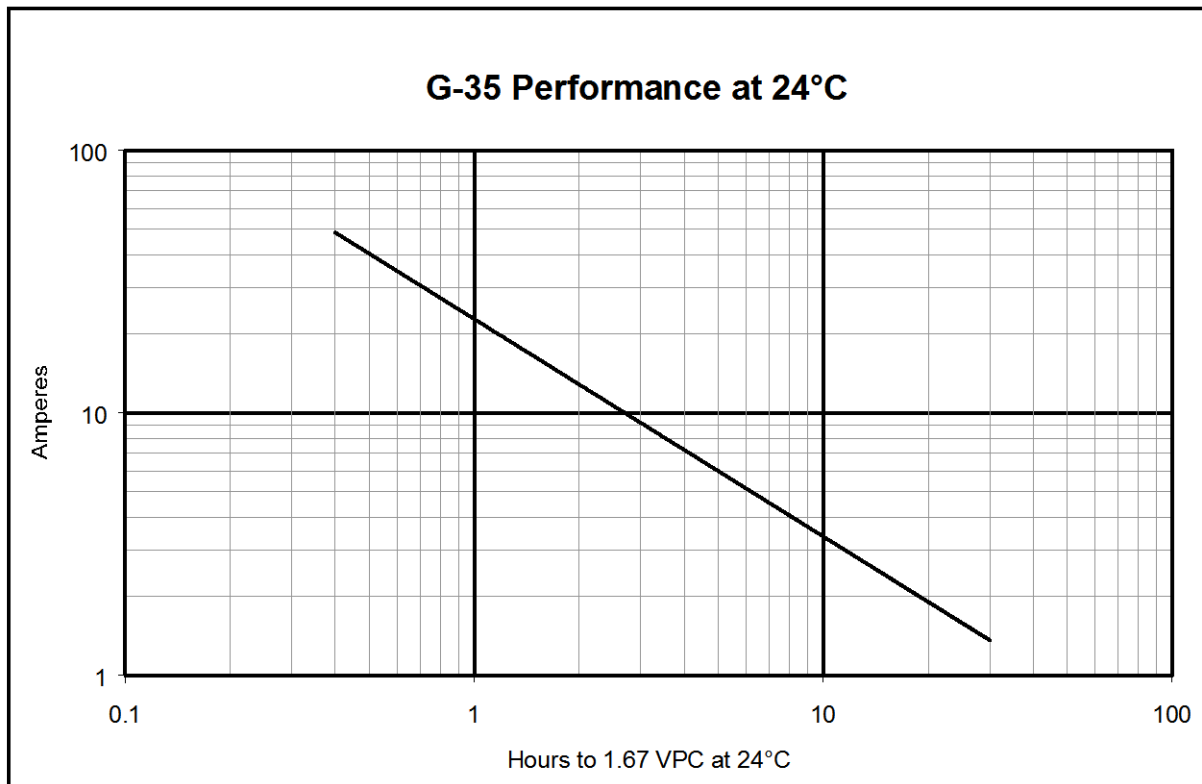



Gill DRY-CHARGE MAINTENANCE MANUAL

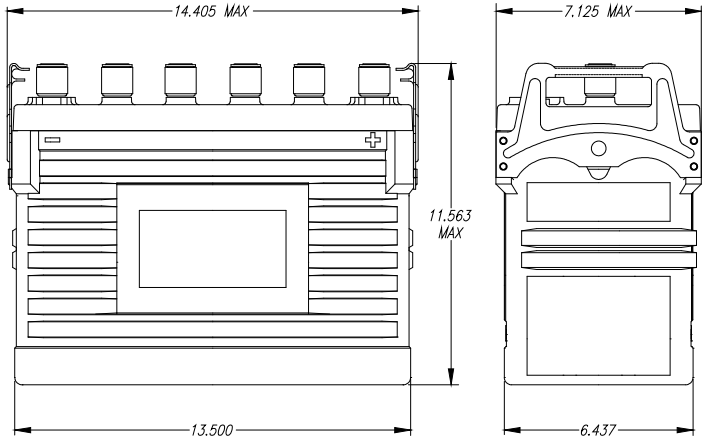

G-88 Performance Data

Run time	End Volts Per Cell	Test Temperature (°C)	Watts	Amps	Capacity (Ah)	Energy (Wh)	Weight (lb)	Electrolyte Volume (quarts)
60 sec	1.2	-18	6,000	500	8	100	78	8
30 min.	1.67	24	1,296	108	54	648		
60 min.			780	65	65	780		

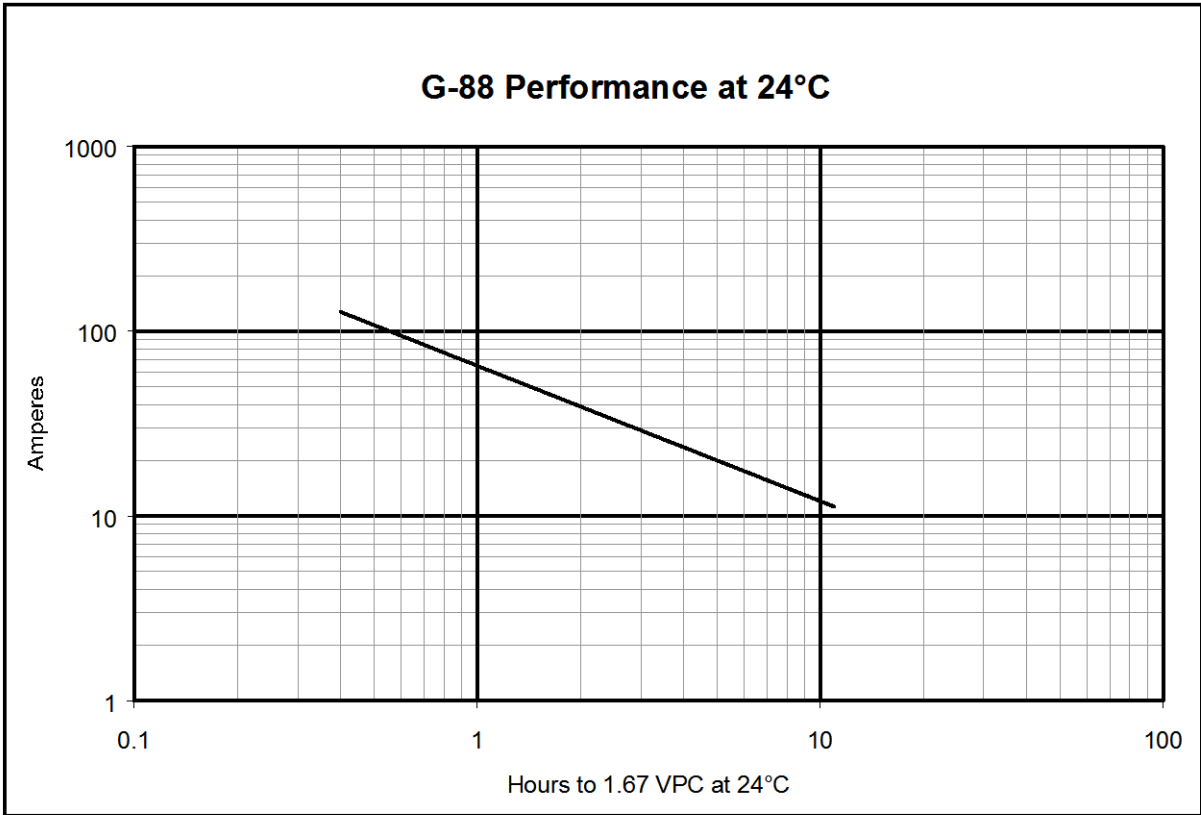

Premium Aircraft Batteries
 TELEDYNE BATTERY PRODUCTS
 www.gilbatteries.com
 800.456.0070



G-240

Gill DRY-CHARGE MAINTENANCE MANUAL

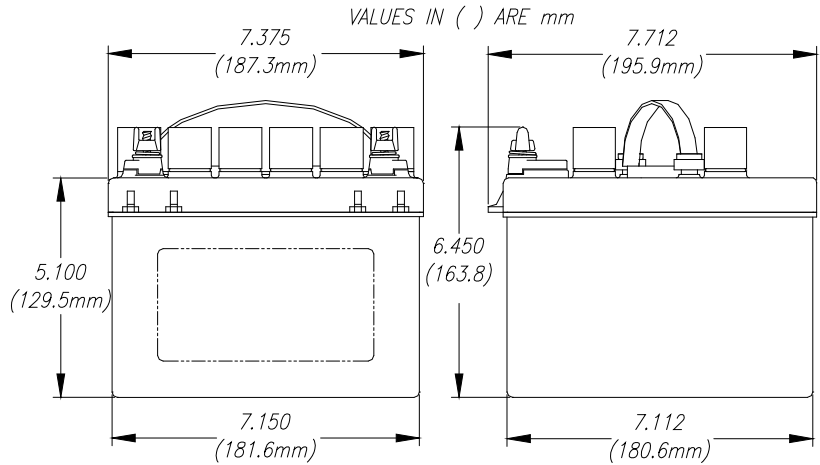

G-240 Performance Data

Run time	End Volts Per Cell	Test Temperature (°C)	Watts	Amps	Capacity (Ah)	Energy (Wh)	Weight (lb)	Electrolyte Volume (quarts)
60 sec	1.2	-18	2,544	106	2	42.4	23.8	3
30 min.	1.67	24	312	13	6.5	156		
60 min.			192	8	8	192		
20 hr.			16	0.67	13.4	321.6		

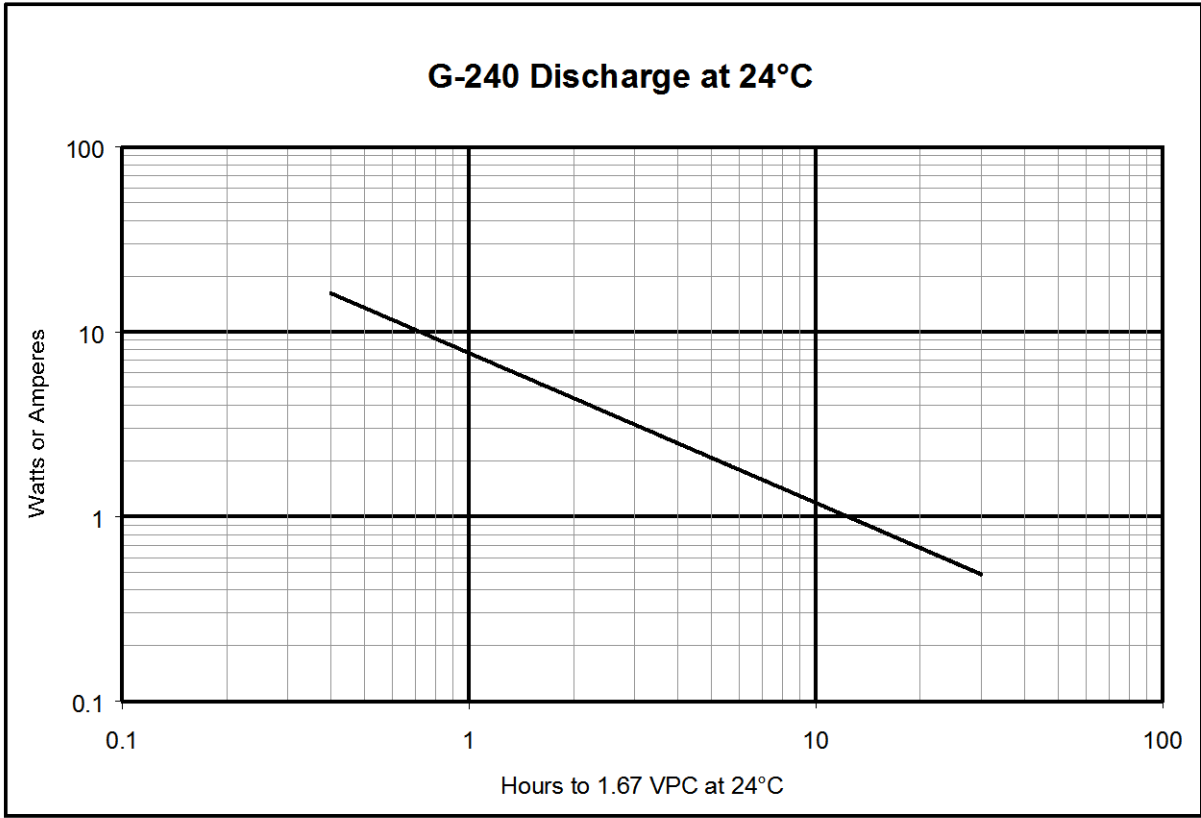

Premium Aircraft Batteries
 TELEDYNE BATTERY PRODUCTS
www.gillbatteries.com
 800.456.0070



Gill DRY-CHARGE MAINTENANCE MANUAL

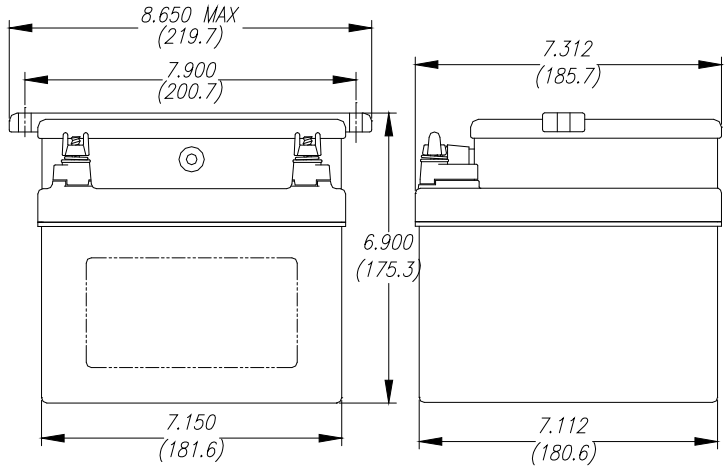

G-241 Performance Data

Run time	End Volts Per Cell	Test Temperature (°C)	Watts	Amps	Capacity (Ah)	Energy (Wh)	Weight (lb)	Electrolyte Volume (quarts)
60 sec	1.2	-18	2,544	106	2	42	24.3	3
30 min.	1.67	24	312	13	6.5	156		
60 min.			192	8	8	192		
20 hr.			16	0.67	13.4	322		

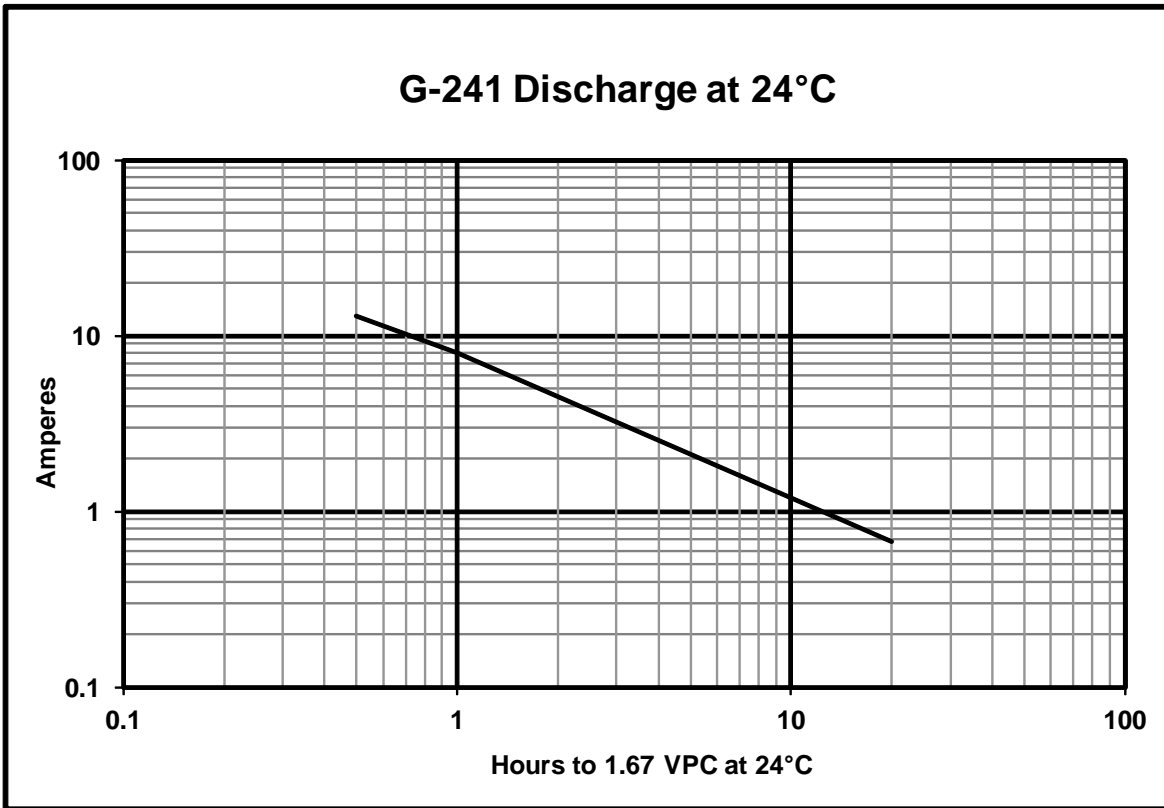

Premium Aircraft Batteries
 TELEDYNE BATTERY PRODUCTS
 www.gilbatteries.com
 800.456.0070



Gill DRY-CHARGE MAINTENANCE MANUAL

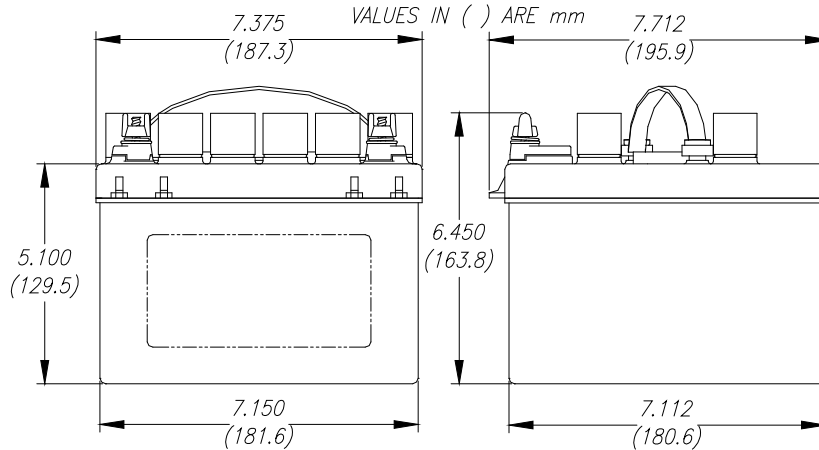

G-242 Performance Data

Run time	End Volts Per Cell	Test Temperature (°C)	Watts	Amps	Capacity (Ah)	Energy (Wh)	Weight (lb)	Electrolyte Volume (quarts)
60 sec	1.2	-18	3600	150	3	60	25.7	3
30 min.	1.67	24	408	17	8.5	204		
60 min.			240	10	10	240		
20 hr.			19.2	0.8	16	384		

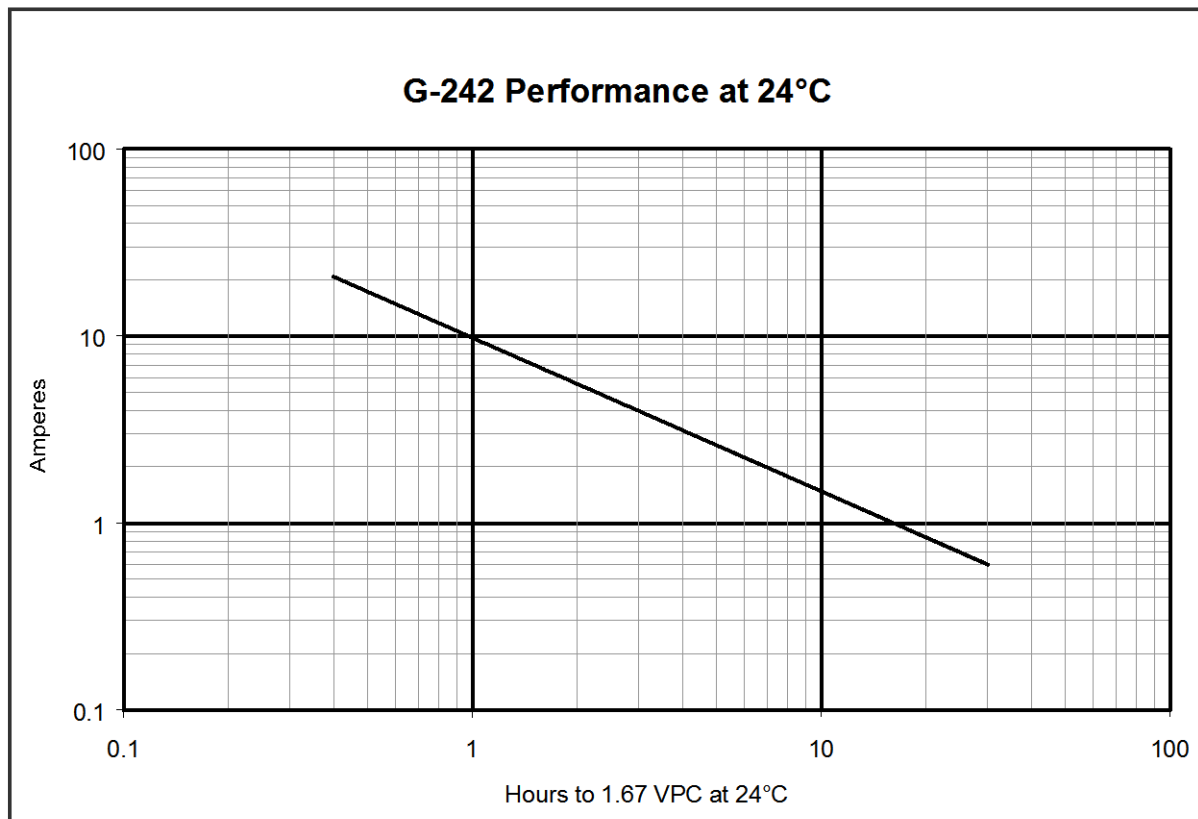



Gill DRY-CHARGE MAINTENANCE MANUAL

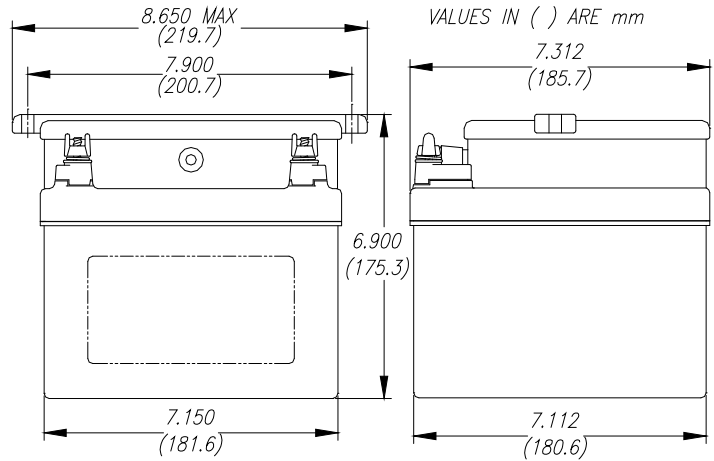

G-243 Performance Data

Run time	End Volts Per Cell	Test Temperature (°C)	Watts	Amps	Capacity (Ah)	Energy (Wh)	Weight (lb)	Electrolyte Volume (quarts)
60 sec	1.2	-18	3,600	150	3	60	26.4	3
30 min.	1.67	24	408	17	8.5	204		
60 min.			240	10	10	240		
20 hr.			19	0.8	16	384		

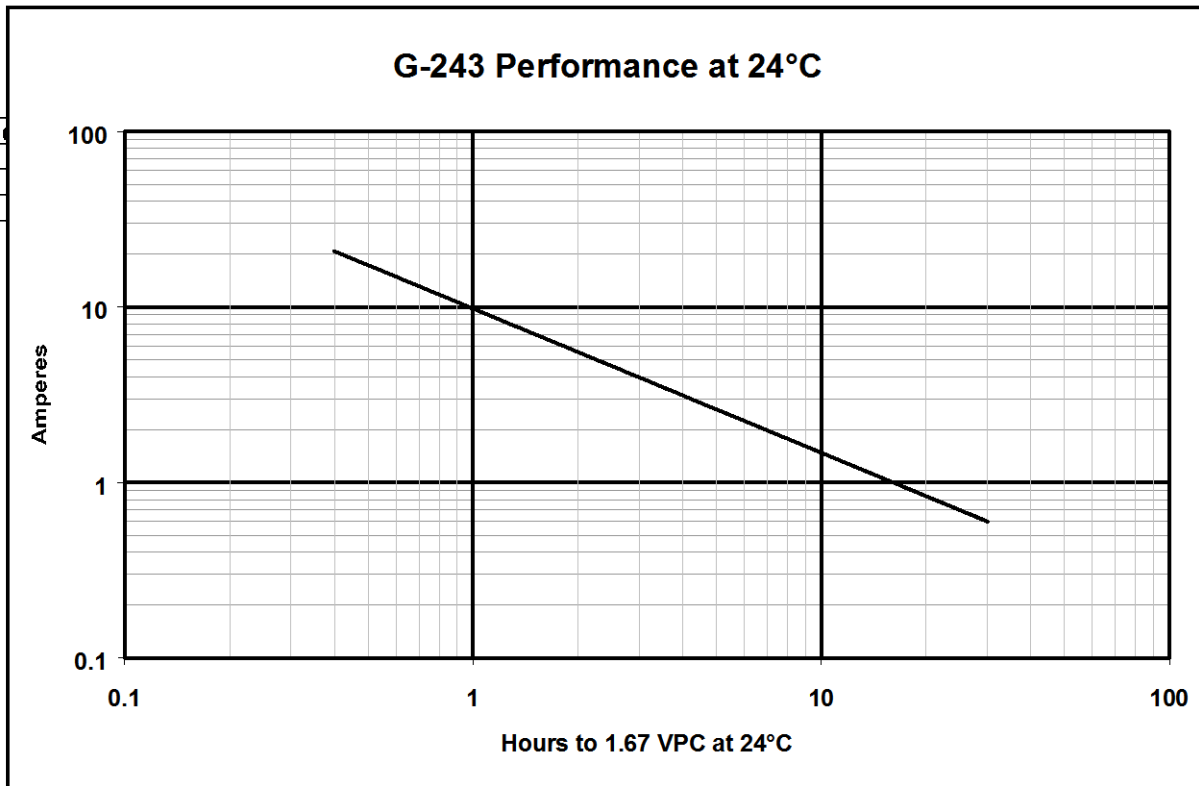

Premium Aircraft Batteries
 TELEDYNE BATTERY PRODUCTS
 www.gilbatteries.com
 800.456.0070



G-244

Gill DRY-CHARGE MAINTENANCE MANUAL

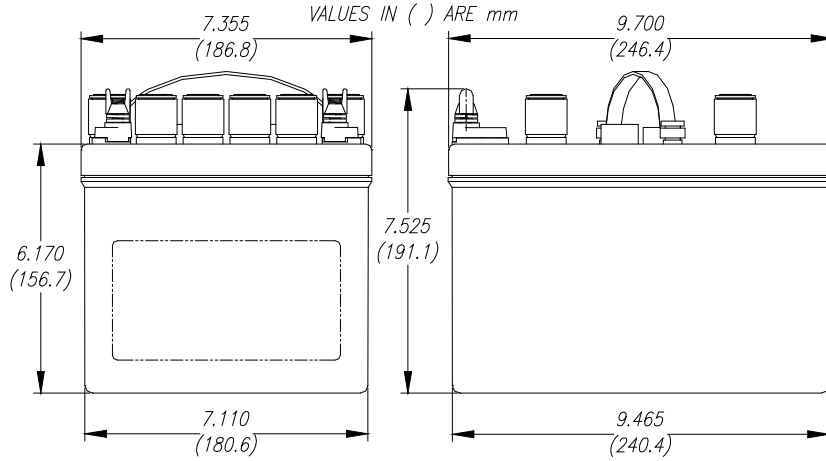

G-244 Performance Data

Run time	End Volts Per Cell	Test Temperature (°C)	Watts	Amps	Capacity (Ah)	Energy (Wh)	Weight (lb)	Electrolyte Volume (quarts)
60 sec	1.2	-18	5,400	225	4	90	38.5	4
30 min.	1.67	24	720	30	15	360		
60 min.			432	18	18	432		
20 hr.			36	1.5	30	720		

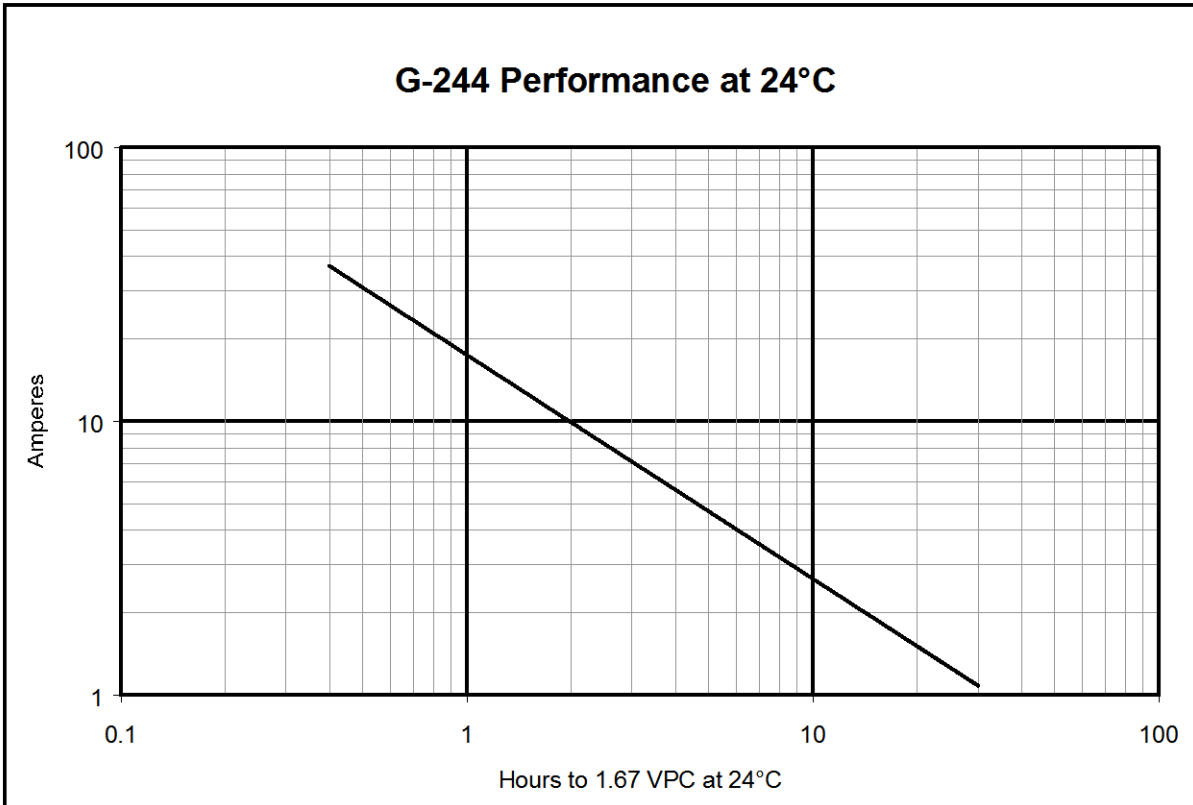

Premium Aircraft Batteries
 TELEDYNE BATTERY PRODUCTS
www.gillbatteries.com
 800.456.0070



Gill DRY-CHARGE MAINTENANCE MANUAL

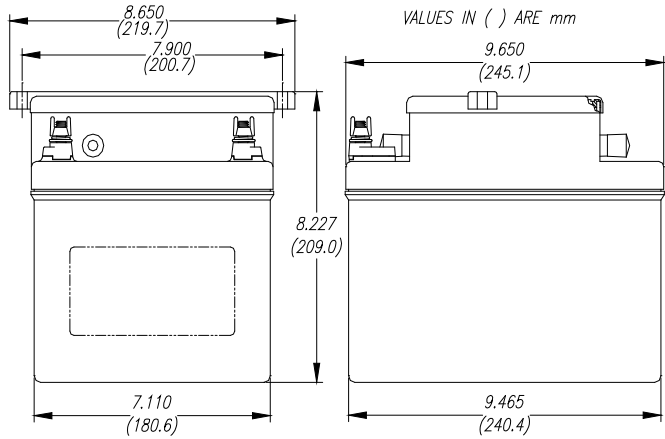

G-245 Performance Data

Run time	End Volts Per Cell	Test Temperature (°C)	Watts	Amps	Capacity (Ah)	Energy (Wh)	Weight (lb)	Electrolyte Volume (quarts)
60 sec	1.2	-18	5,400	225	4	90	39.5	4
30 min.	1.67	24	720	30	15	360		
60 min.			432	18	18	432		
20 hr.			36	1.5	30	720		

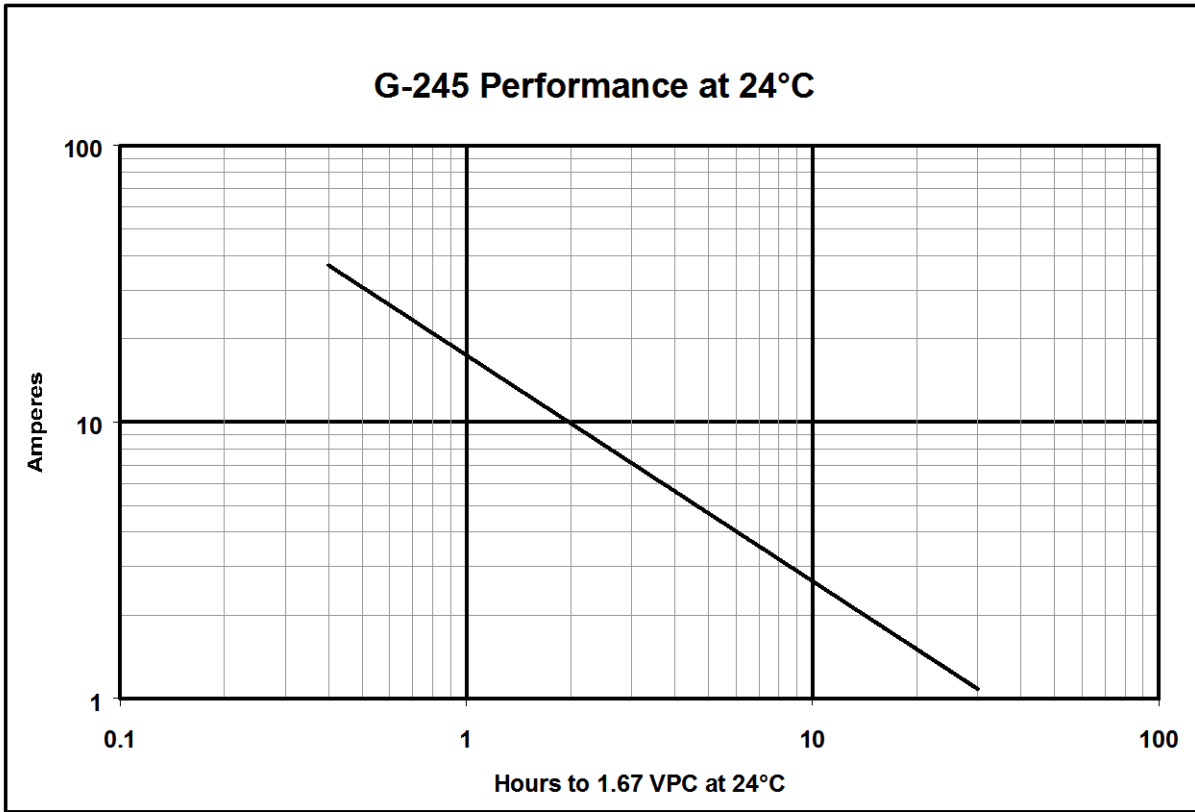

Premium Aircraft Batteries
 TELEDYNE BATTERY PRODUCTS
 www.gilbatteries.com
 800.456.0070



Gill DRY-CHARGE MAINTENANCE MANUAL

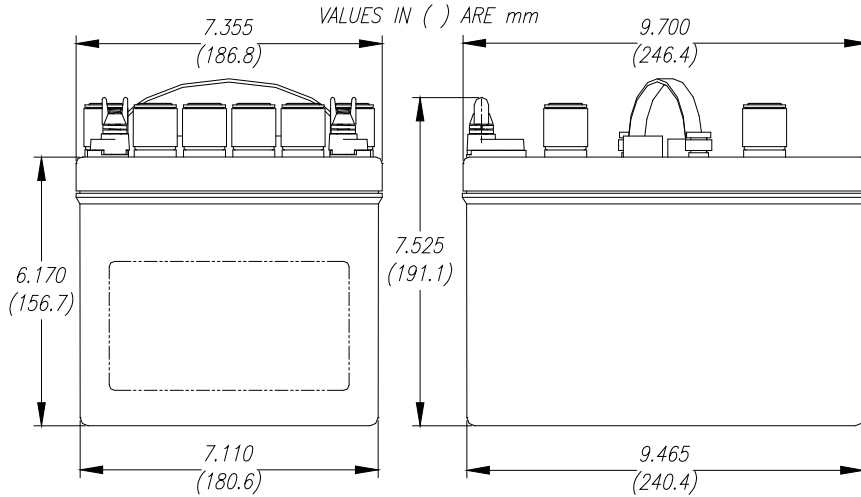

G-246 Performance Data

Run time	End Volts Per Cell	Test Temperature (°C)	Watts	Amps	Capacity (Ah)	Energy (Wh)	Weight (lb)	Electrolyte Volume (quarts)
60 sec	1.2	-18	6,000	250	4	100	42	4
30 min.	1.67	24	768	32	16	384		
60 min.			456	19	19	456		
20 hr.			38	1.6	32	768		

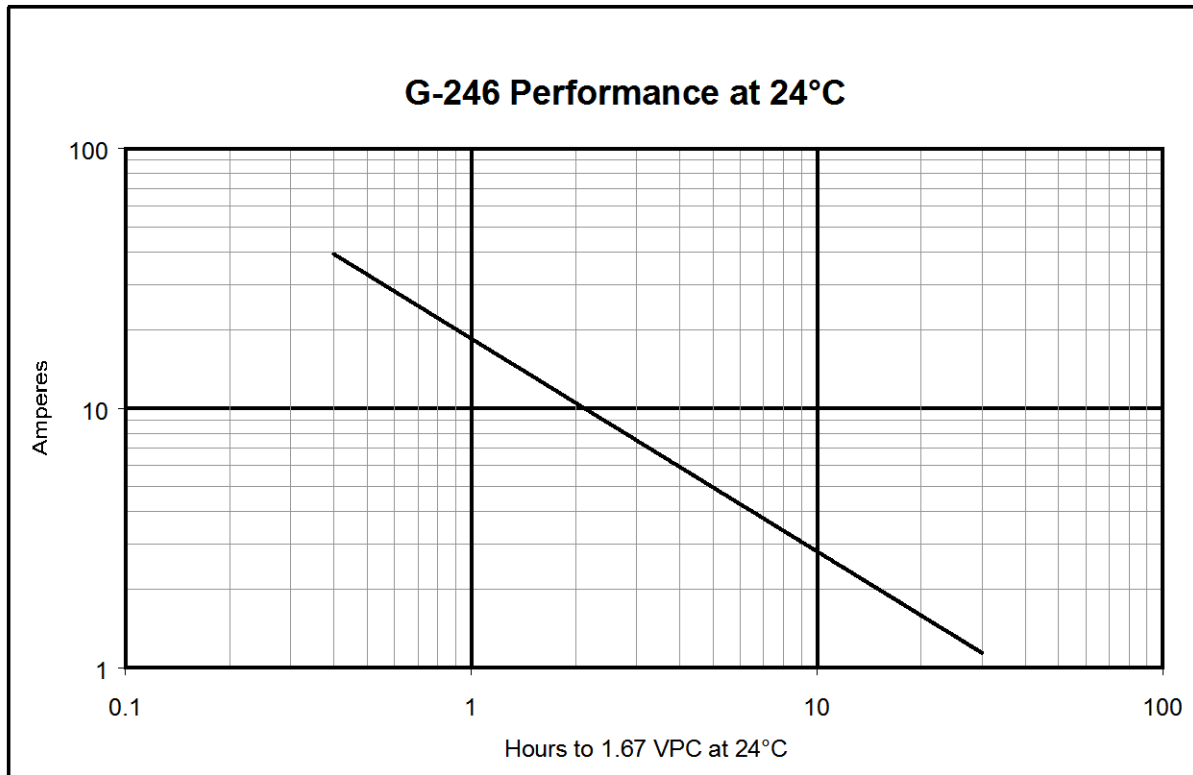



G-247

Gill DRY-CHARGE MAINTENANCE MANUAL

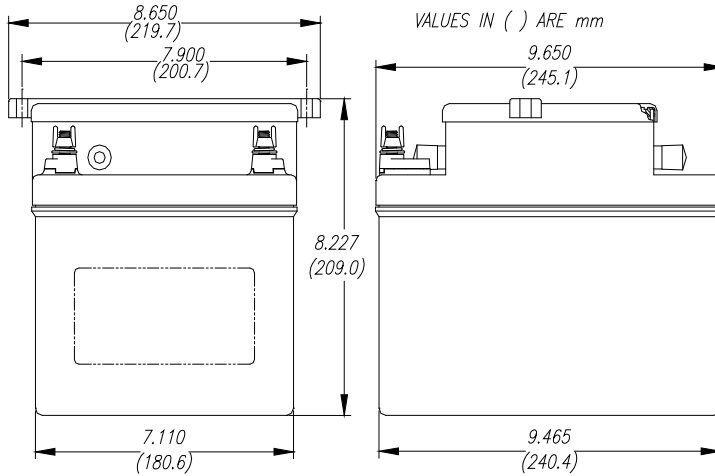

G-247 Performance Data

Run time	End Volts Per Cell	Test Temperature (°C)	Watts	Amps	Capacity (Ah)	Energy (Wh)	Weight (lb)	Electrolyte Volume (quarts)
60 sec	1.2	-18	6,000	250	4	100	42.5	4
30 min.	1.67	24	768	32	16	384		
60 min.			456	19	19	456		
20 hr.			38	1.6	32	768		

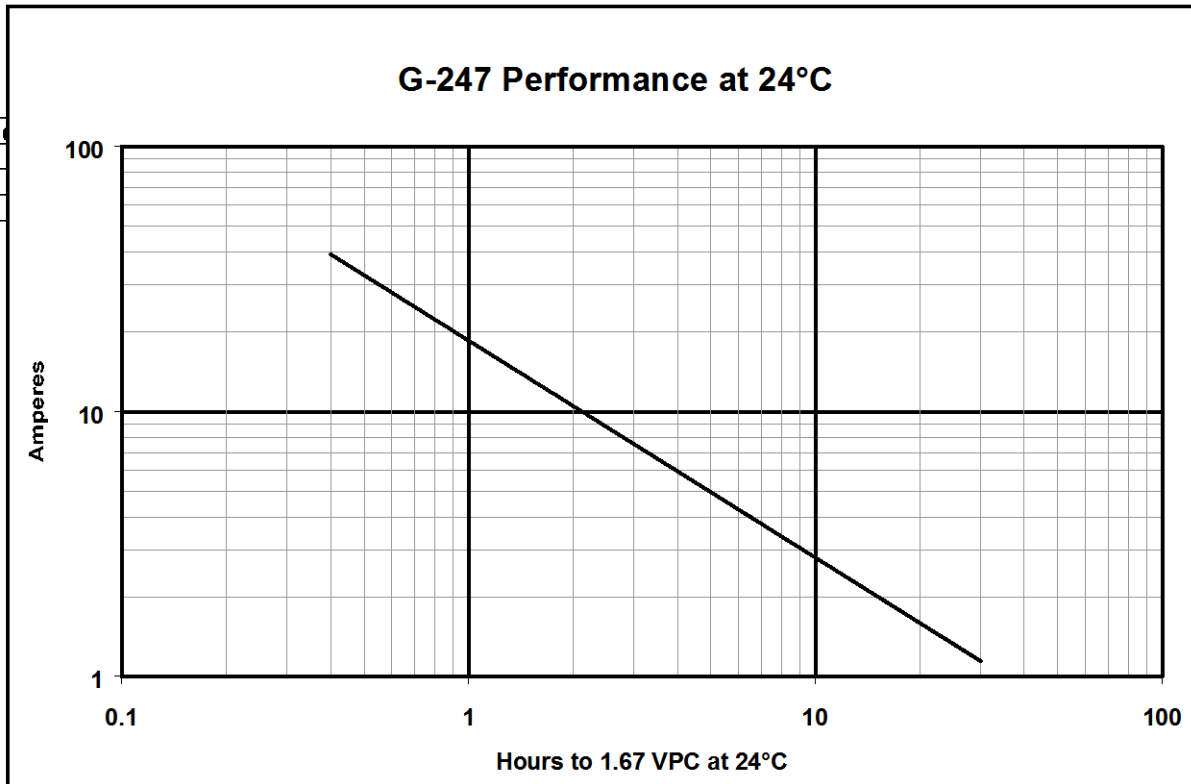

Premium Aircraft Batteries
 TELEDYNE BATTERY PRODUCTS
www.gilbatteries.com
 800.456.0070



Gill DRY-CHARGE MAINTENANCE MANUAL

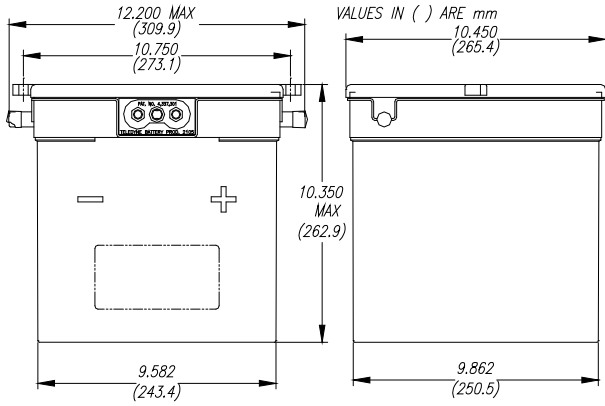

G-6381E

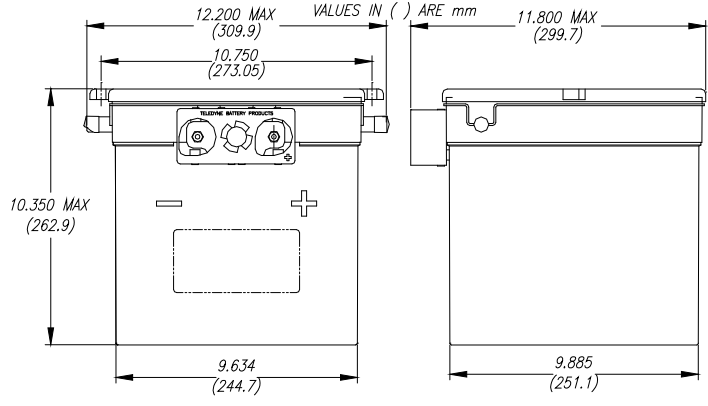

G-6381C

G-6381E/C Performance Data

Run time	End Volts Per Cell	Test Temperature (°C)	Watts	Amps	Capacity (Ah)	Energy (Wh)	Weight (lb)	Electrolyte Volume (quarts)
60 sec	1.2	-18	10,680	445	7	178	81	9
30 min.	1.67	24	1,680	70	35	840		
60 min.			1,032	43	43	1,032		
20 hr.			86	3.6	72	1,728		

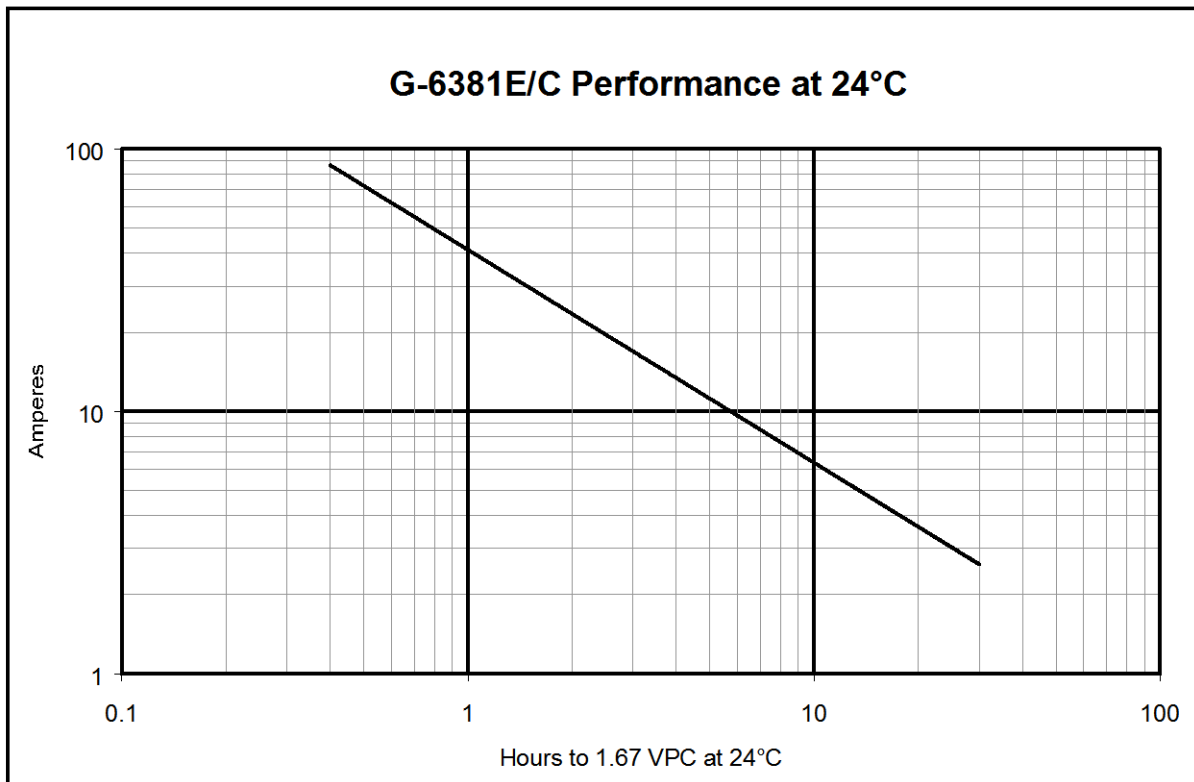

Premium Aircraft Batteries
TELEDYNE BATTERY PRODUCTS
www.gilbatteries.com
800.456.0070



Gill DRY-CHARGE MAINTENANCE MANUAL

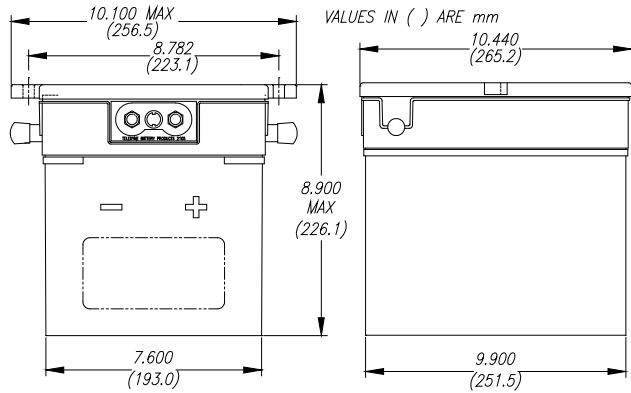

G-639E

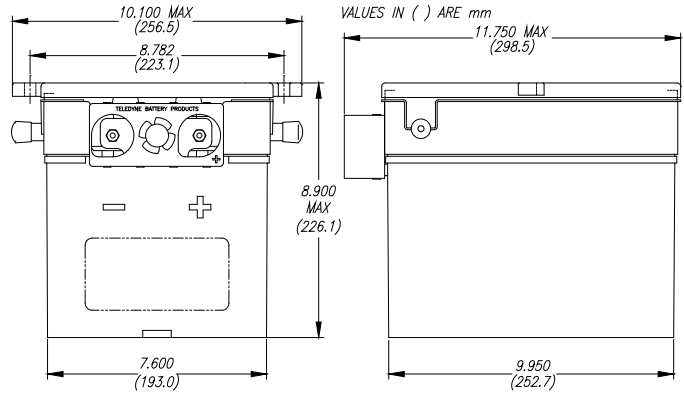

G-639C

G-639E/C Performance Data

Run time	End Volts Per Cell	Test Temperature (°C)	Watts	Amps	Capacity (Ah)	Energy (Wh)	Weight (lb)	Electrolyte Volume (quarts)
60 sec	1.2	-18	8,280	345	6	138	55	4
30 min.	1.67	24	960	40	20	480		
60 min.			576	24	24	576		
20 hr.			48	2	40	960		

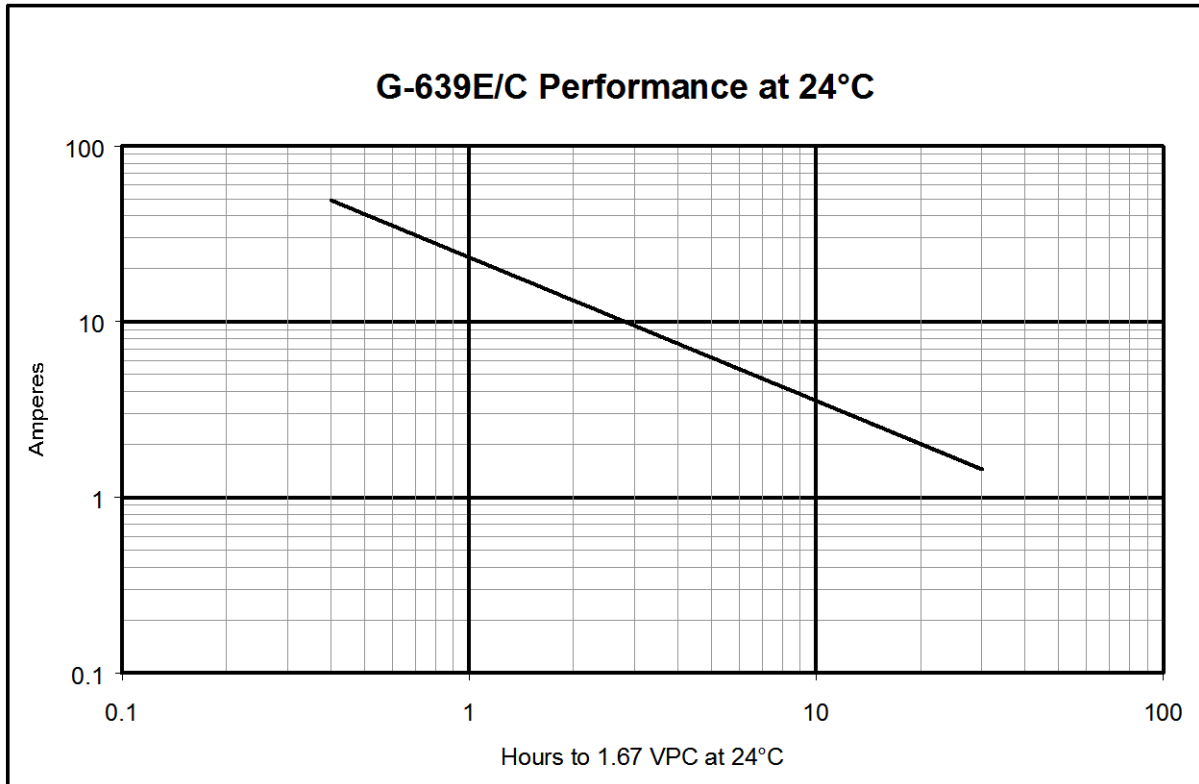

Premium Aircraft Batteries
 TELEDYNE BATTERY PRODUCTS
 www.gilbatteries.com
 800.456.0070



Gill DRY-CHARGE MAINTENANCE MANUAL

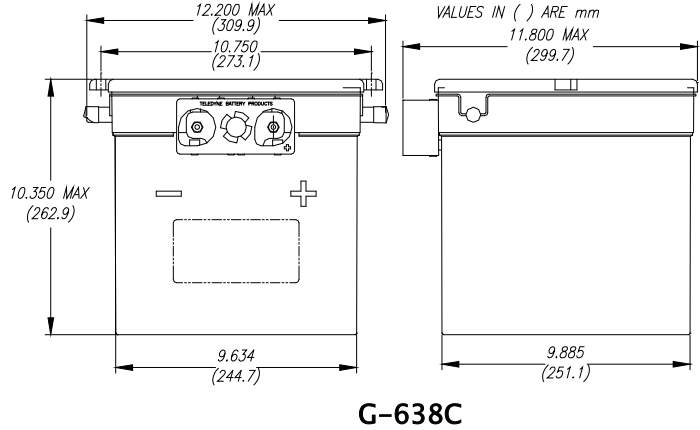
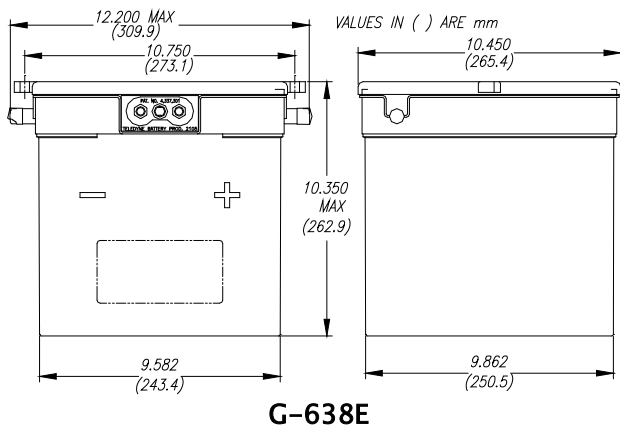

G-638E/C Performance Data

Run time	End Volts Per Cell	Test Temperature (°C)	Watts	Amps	Capacity (Ah)	Energy (Wh)	Weight (lb)	Electrolyte Volume (quarts)
60 sec	1.2	-18	9,000	375	6	150	80	9
30 min.	1.67	24	1,440	60	30	720		
60 min.			888	37	37	888		
20 hr.			74	3	62	1,480		

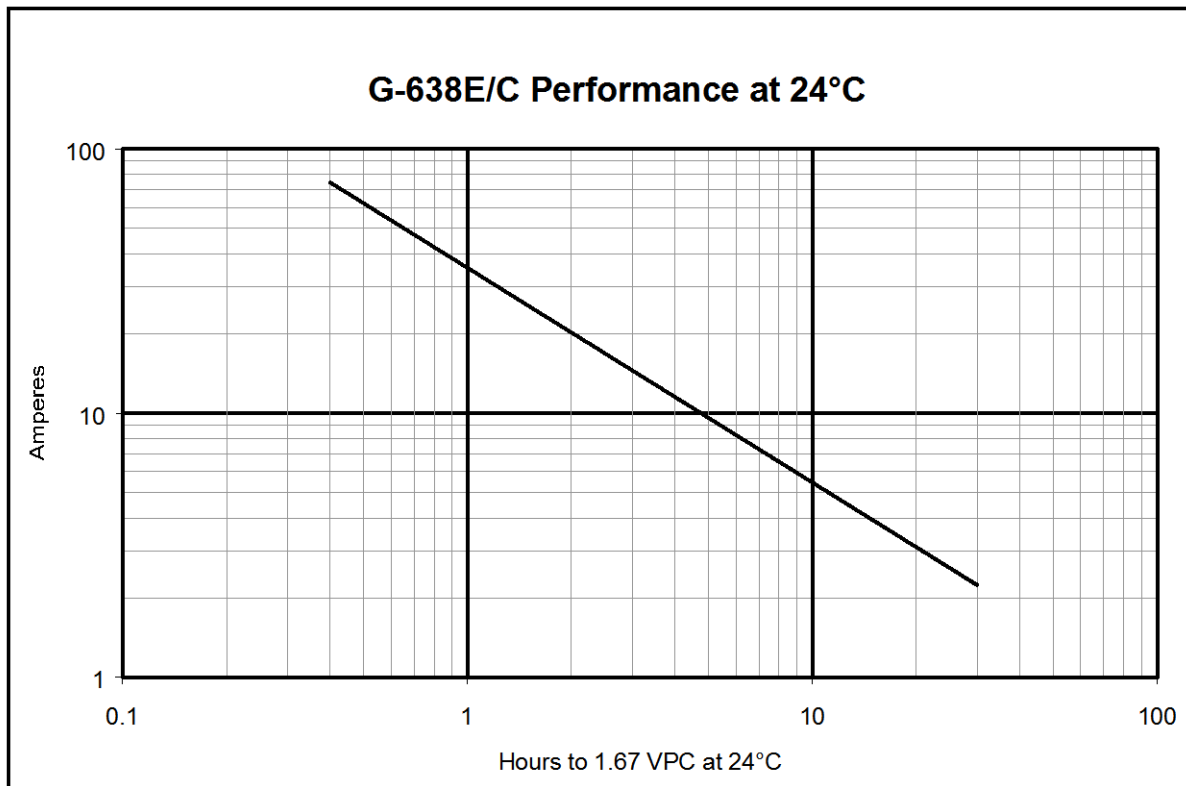

Premium Aircraft Batteries
TELEDYNE BATTERY PRODUCTS
www.gilbatteries.com
800.456.0070



Gill DRY-CHARGE MAINTENANCE MANUAL

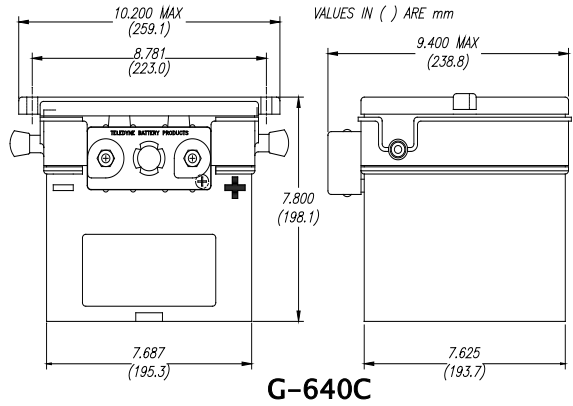
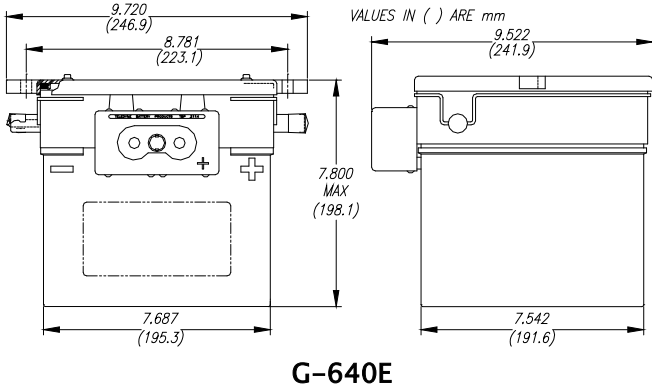

G-640E/C Performance Data

Run time	End Volts Per Cell	Test Temperature (°C)	Watts	Amps	Capacity (Ah)	Energy (Wh)	Weight (lb)	Electrolyte Volume (quarts)
60 sec	1.2	-18	4,320	180	3	72	35	3
30 min.	1.67	24	600	25	13	300		
60 min.			336	14	14	336		
20 hr.			26	1.1	22	528		

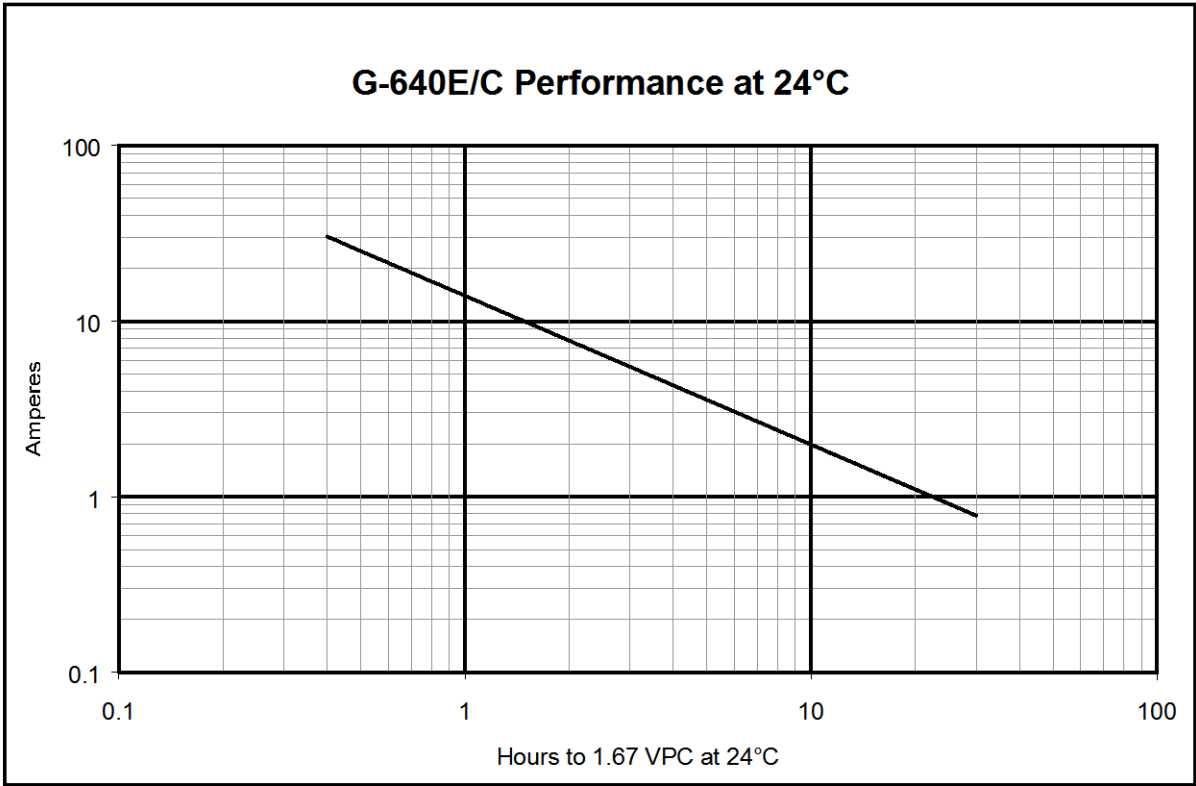

Premium Aircraft Batteries
 TELEDYNE BATTERY PRODUCTS
www.gilbatteries.com
 800.456.0070



Gill DRY-CHARGE MAINTENANCE MANUAL

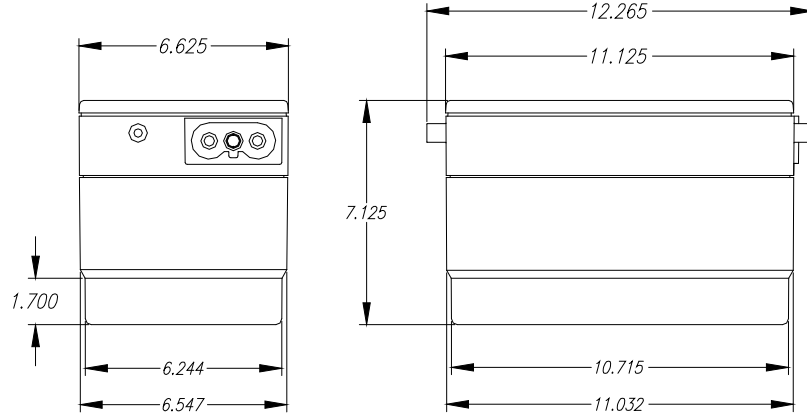

G-641 Performance Data

Run time	End Volts Per Cell	Test Temperature (°C)	Watts	Amps	Capacity (Ah)	Energy (Wh)	Weight (lb)	Electrolyte Volume (quarts)
60 sec	1.2	-18	6,600	275	5	110	41.5	4
30 min.	1.67	24	720	30	15	360		
60 min.			432	18	18	432		
20 hr.			36	1.5	30	720		

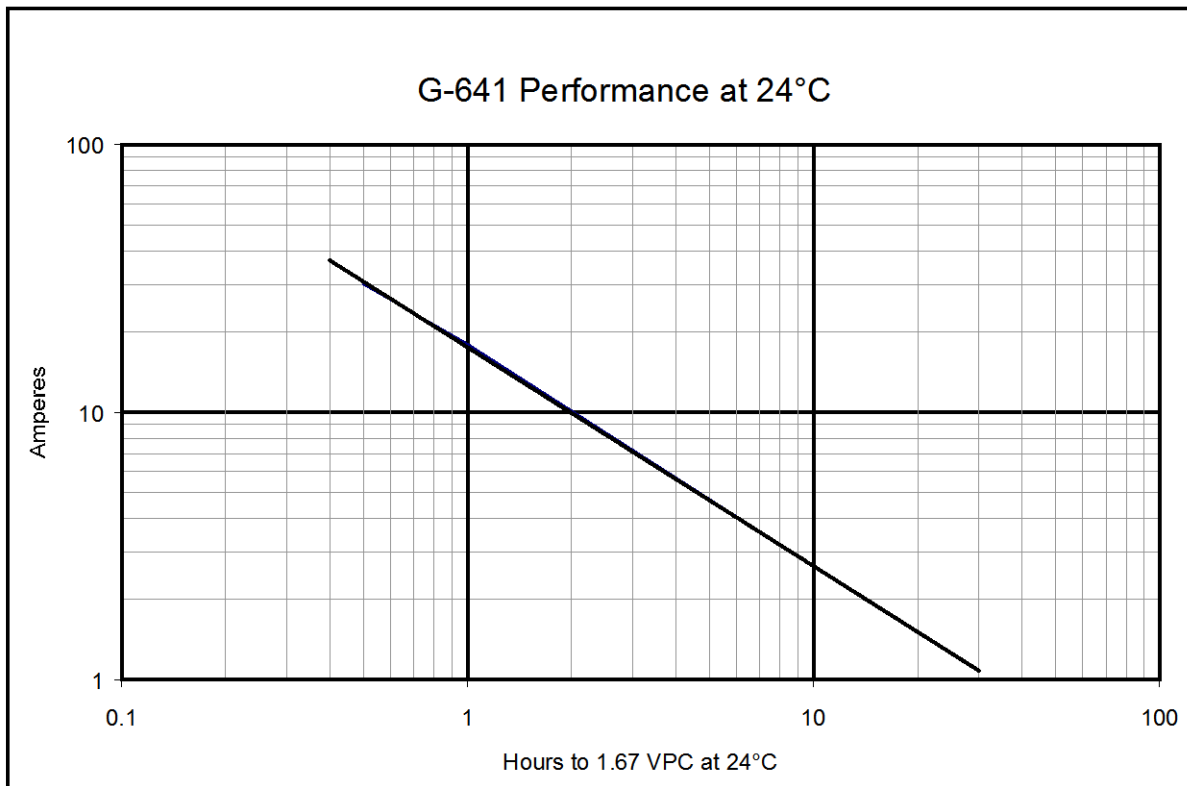

Premium Aircraft Batteries
 TELEDYNE BATTERY PRODUCTS
www.gilbatteries.com
 800.456.0070



GE-50C

Gill DRY-CHARGE MAINTENANCE MANUAL

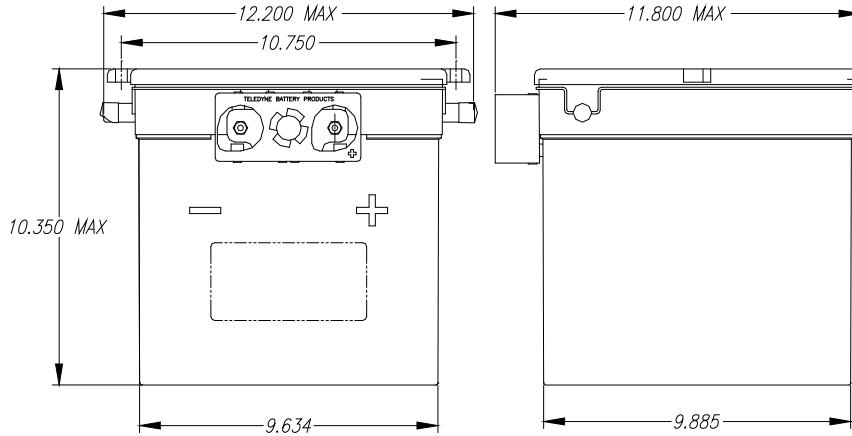

GE-50C Performance Data

Run time	End Volts Per Cell	Test Temperature (°C)	Watts	Amps	Capacity (Ah)	Energy (Wh)	Weight (lb)	Electrolyte Volume (quarts)
60 sec	1.2	-18	7,800	325	5	130	80	8
30 min.	1.67	24	1,320	55	28	660		
60 min.			744	31	31	744		
20 hr.			60	3	50	1,200		

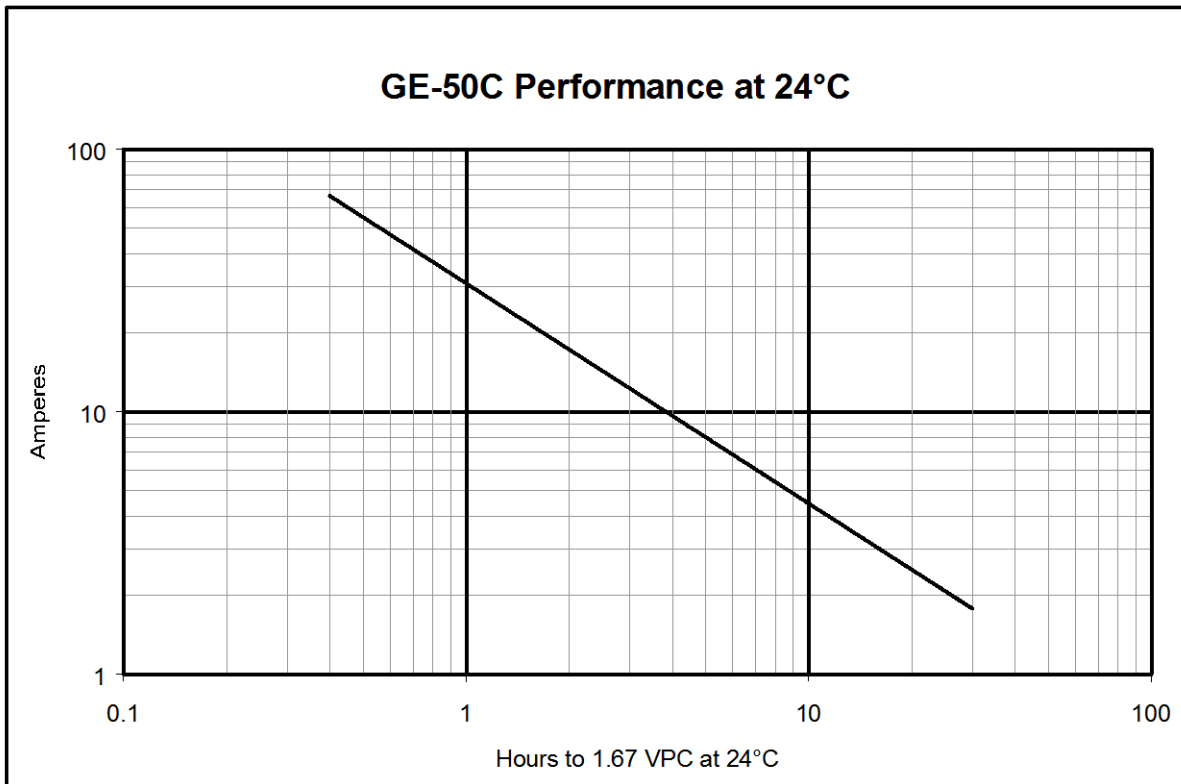

Premium Aircraft Batteries
 TELEDYNE BATTERY PRODUCTS
www.gilbatteries.com
 800.456.0070



GE-51C

Gill DRY-CHARGE MAINTENANCE MANUAL

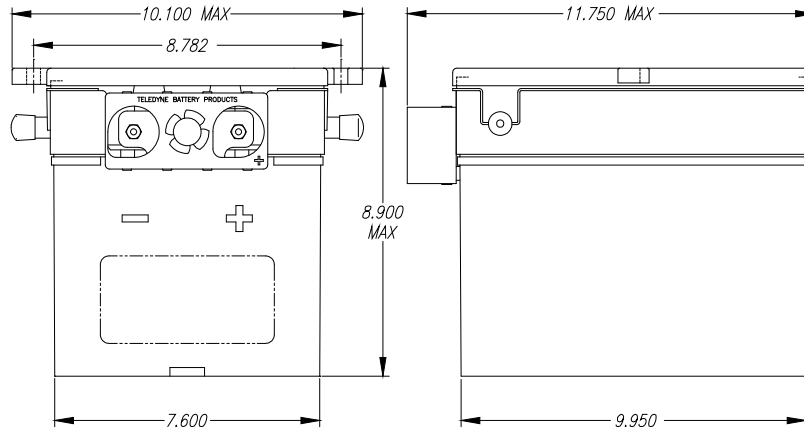

GE-51C Performance Data

Run time	End Volts Per Cell	Test Temperature (°C)	Watts	Amps	Capacity (Ah)	Energy (Wh)	Weight (lb)	Electrolyte Volume (quarts)
60 sec	1.2	-18	5,640	235	4	94	52	5
30 min.	1.67	24	840	35	18	420		
60 min.			528	22	22	528		
20 hr.			43	1.8	36	864		

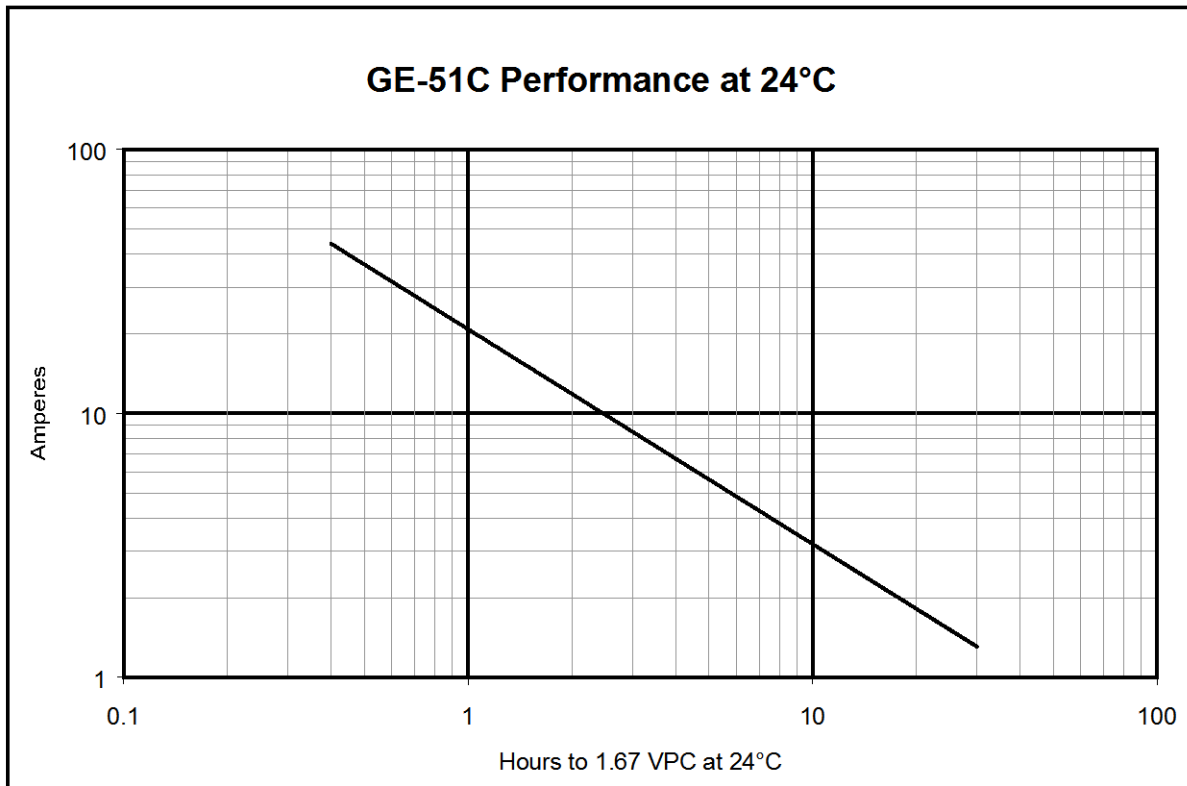

Premium Aircraft Batteries
 TELEDYNE BATTERY PRODUCTS
www.gilbatteries.com
 800.456.0070



GE-54C

Gill DRY-CHARGE MAINTENANCE MANUAL

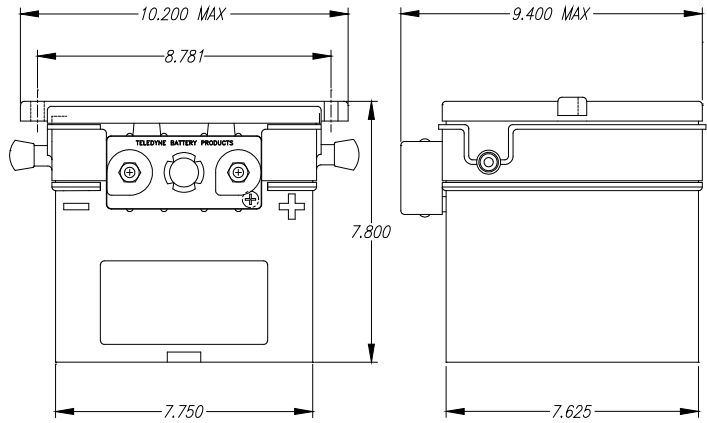

GE-54C Performance Data

Run time	End Volts Per Cell	Test Temperature (°C)	Watts	Amps	Capacity (Ah)	Energy (Wh)	Weight (lb)	Electrolyte Volume (quarts)
60 sec	1.2	-18	2,544	106	2	42	34	3
30 min.			384	16	8	192		
60 min.	1.67	24	240	10	10	240		
20 hr.			19	0.8	16	384		

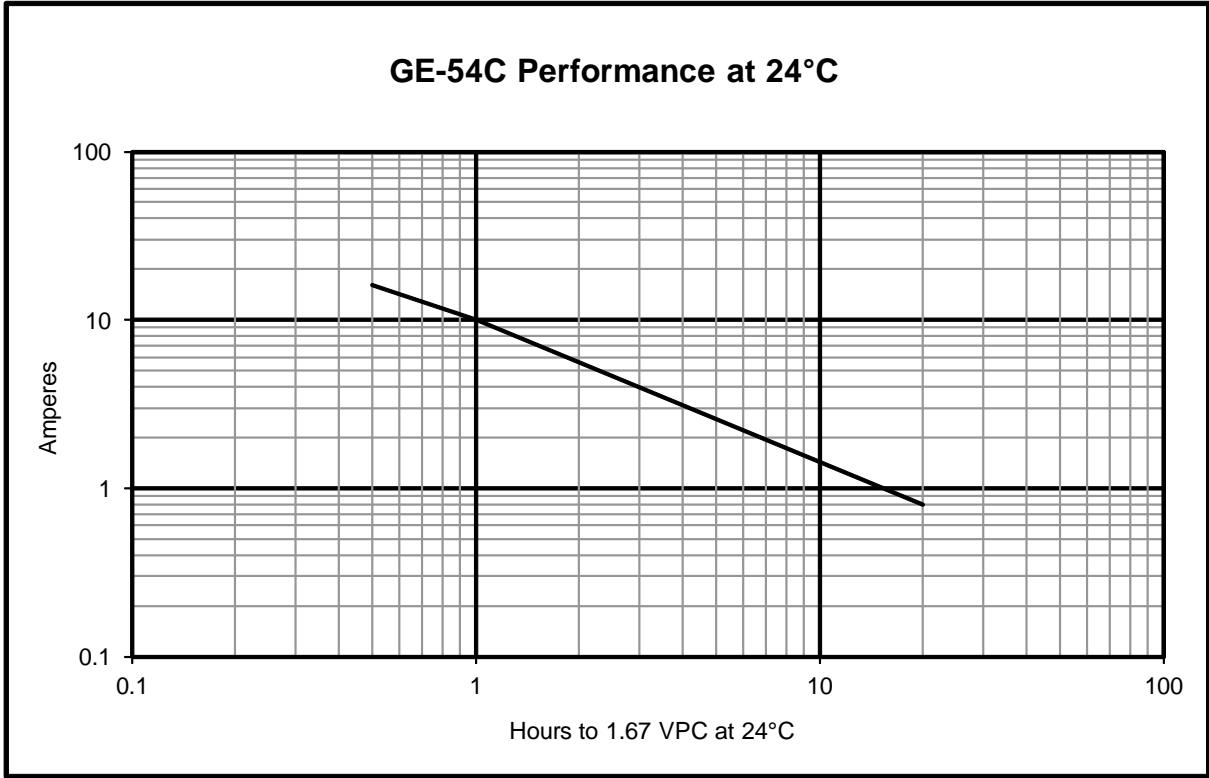

Premium Aircraft Batteries
 TELEDYNE BATTERY PRODUCTS
www.gilbatteries.com
 800.456.0070



Gill DRY-CHARGE MAINTENANCE MANUAL

APPENDIX B

Using a Hydrometer

Hydrometers are used to determine specific gravity of liquids. Specific gravity is a ratio of the density of the substance measured versus the density of pure water at the same temperature. Thus specific gravity will vary with temperature. Note Figure 5.

A hydrometer consists of a small sealed glass tube, weighted at one end to make it float in an upright position in the fluid being measured. See Figure 4.

Figure 4

Hydrometer

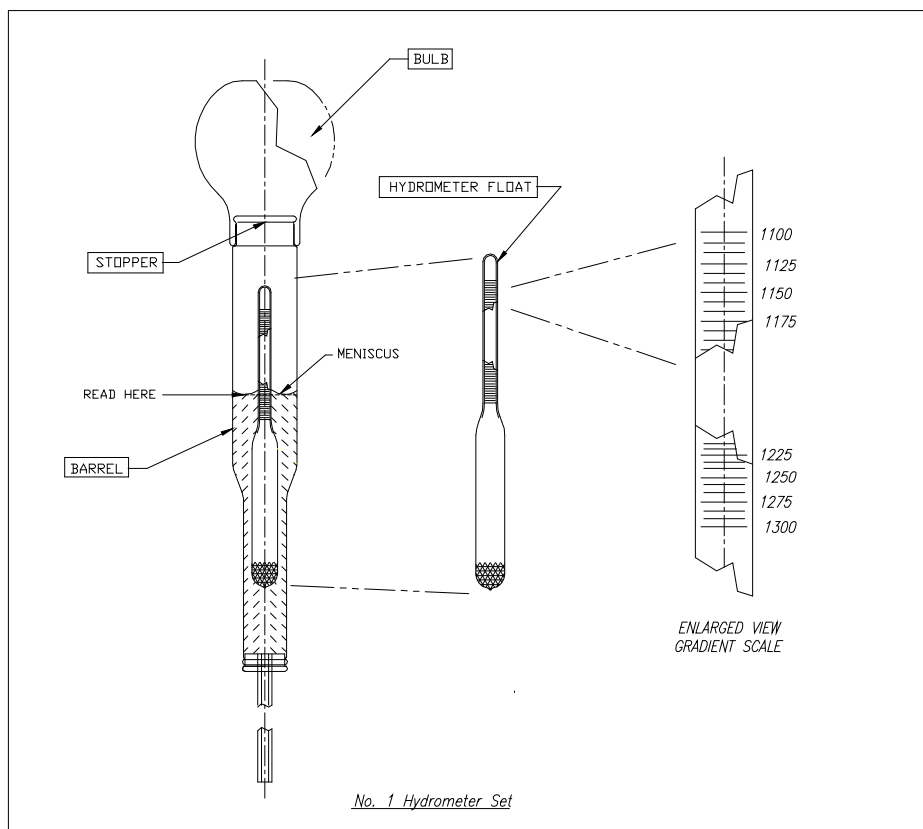



Gill DRY-CHARGE MAINTENANCE MANUAL

The liquid being measured will be pulled in the barrel such that the hydrometer floats on the liquid (without touching the stopper at the base of the rubber bulb). The meniscus will be convex and the actual gravity reading will be taken at the base of the meniscus.

Verify the resolution (value per increment on the bulb of the hydrometer) on the hydrometer scale and use appropriate temperature correction as indicated on the scale, Figure 5.

**Figure 5
Temperature Correction Scale**

TEMPERATURE CORRECTION USING A HYDROMETER CALIBRATED FOR ZERO CORRECTION AT 80°F					
60°F	70°F	80°F	90°F	100°F	110°F
-8	-4	0	+4	+8	+12
SUBTRACT FROM READING			ADD TO READING		

Temperature Correction

When using an 80/80 hydrometer, use the correction values indicated in Figure 5. As the electrolyte cools down, the measured specific gravity will increase, and vice versa when the electrolyte warms up.

The true specific gravity is subsequently determined by applying the appropriate correction for temperature. This correction is calculated as follows:

If the measured hydrometer reading (or specific gravity) is 1.275 and the temperature of the electrolyte is 60°F, then you would subtract 8 points to obtain the actual specific gravity:

$$1.275 - 0.008 = 1.267$$

Similarly, if the temperature were 110°F, then you would add 12 points:

$$1.275 + 0.012 = 1.287$$



Gill DRY-CHARGE MAINTENANCE MANUAL

APPENDIX C

Latest activation instructions are included with the battery. A copy may be obtained from Teledyne Battery Products through the website: www.gillbatteries.com

Premium Aircraft Batteries

TELEDYNE BATTERY PRODUCTS

www.gillbatteries.com

800.456.0070